



Ice **STRIKER™**



OWNER'S MANUAL

400 L TRACTOR SPREADER

GENERAL INFORMATION 3

 Spreader parts 3

 Technical information 4

 Amperage draw at full speed (approx.) 4

SAFETY INFORMATION 5

 Safety definitions 5

 Safety precautions 5

 Recommended vehicle requirements 6

 Noise 6

 Personal safety 6

 Emergency stop 6

 Warning and caution labels 7

INSTALLATION AND OPERATION 8

 Accessory cables 8

 Control placement 8

 Mounting the spreader 8

 Opening tarp cover 9

 Rotate jammed auger manually 9

 Adjustable invert-V 10

 Spreading symmetry adjustment 11

 End of material sensor 12

 Calibration of end of material sensor 13

 Electrical installation of end of material sensor 13

 Average material weights 14

 Removing the spreader 14

MAINTENANCE 15

 Maintaining the spreader 15

 Storage 16

 Greasing points 17

ELECTRICAL SCHEMATIC 18

WARRANTY INFORMATION 19

CERTIFICATE OF CONFORMITY 20

	<p>CAUTION</p> <p>Read this manual before installing or operating the spreader</p>
---	---

Spreader parts

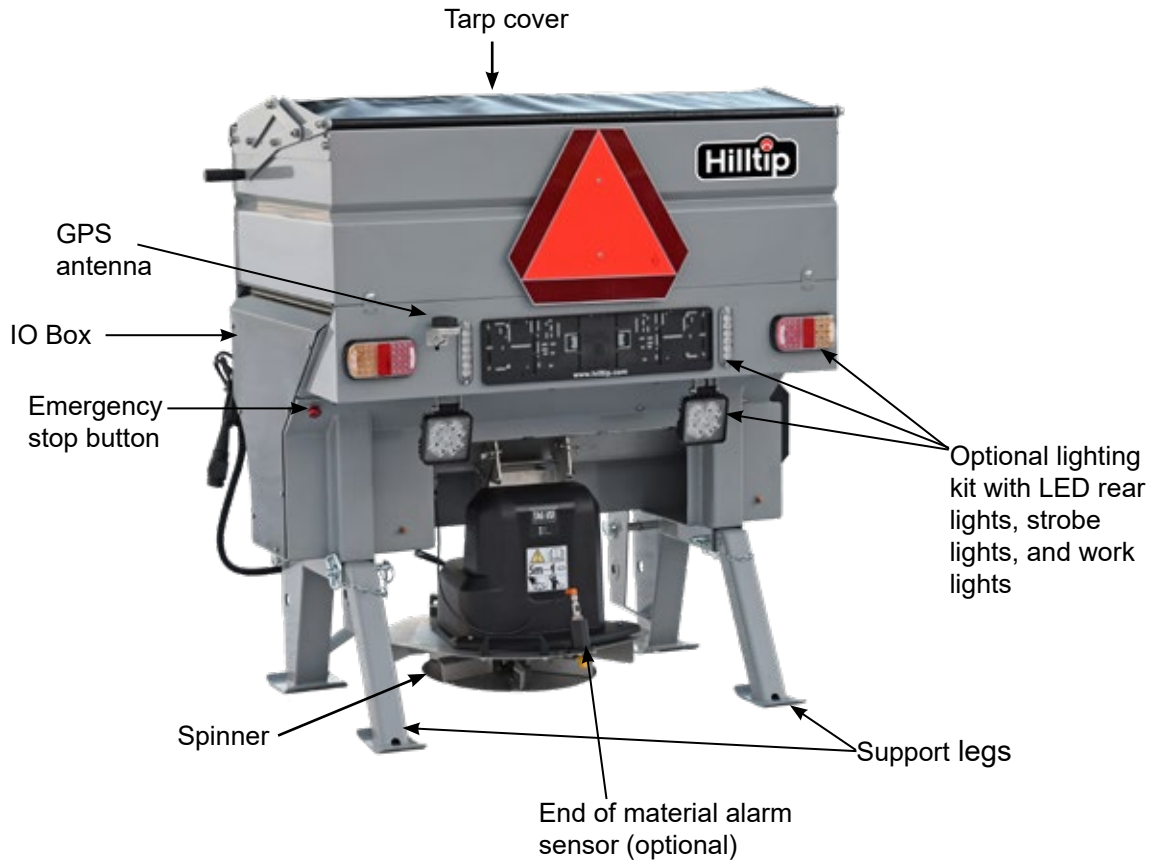

IceStriker™ 550SS TR

Technical information 400SS TR

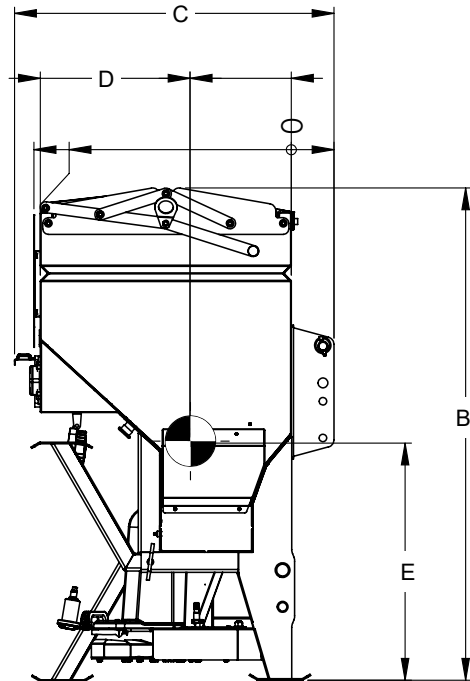
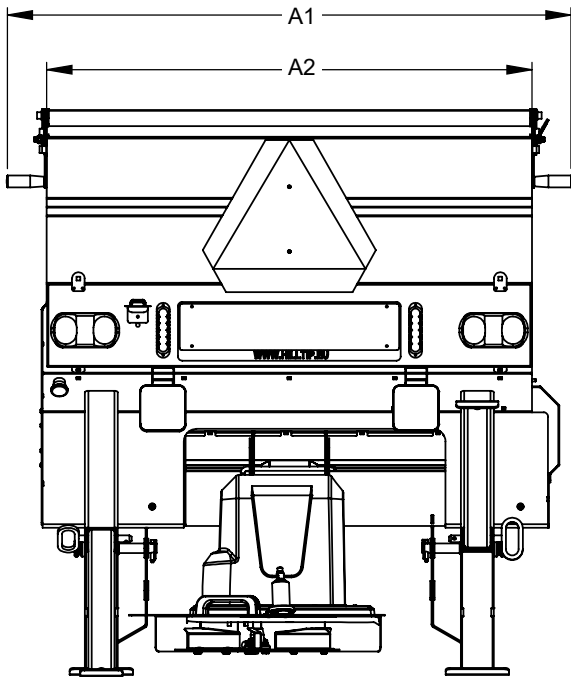

Key	Description	400SS TR
A1	Overall width	134 cm
A2	Hopper width	115 cm
B	Height	134 cm
C	Depth	87 cm
D	Distance from the centre of gravity to the rear part of the spreader hopper (empty spreader)	41 cm
E	Height of the centre of gravity from the spreader's lowest part (empty spreader)	65 cm

Description	400SS TR
Hopper construction	Stainless steel
Spreading width, min -max	1-8 m (may vary depending on material)
Spinner size	390 mm
Auger diameter (stainless steel)	115 mm
Material	Salt, Sand, Granulate/Mixed (max 8mm Ø)
Hopper volume, struck	380 L
Hopper volume, rounded	400 L
Empty spreader weight	265 kg
Full loaded spreader solid material, <i>struck volume</i>	797 kg
Full loaded spreader solid material, <i>rounded volume</i>	825 kg

These numbers are only guidelines, and based on solid materials with a density of 1400 kg/m³.

Specifications are subject to change without notice. We do not take any responsibility in any direct or indirect damages or warranty cases concerning the values above.

Amperage draw at full speed (approx.)

IceStriker™ 400SS TR	Empty	Full
Auger motor	9-13A	15-23A
Spinner motor	10-15A	15-20A

Safety definitions

 **WARNING**
 Implies a potentially hazardous situation that, if not avoided, could result in death or serious personal injury.

 **NOTE**
 Implies a situation or action that can lead to damage to your spreader and vehicle or other property. Other useful information can also be described.

 **CAUTION**
 Implies a potentially hazardous situation that, if not avoided, may result in minor or moderate injury. It may also be used to alert against unsafe practices.

Safety precautions

Incorrect installation and operation can lead to serious personal injury and/or damage your equipment and property. Note and ensure that you understand this manual and all the labels before installing, operating or making adjustments to the spreader.

 **WARNING**
 Observe these safety precautions before, during and after operating the spreader. You can prevent injury to persons and damage to the spreader by following these precautions.

 **WARNING**
 Warning - Disconnect power and wait for spinner and auger to stop completely before servicing, opening the cover to the technical housing or removing the top screen. The auger is fully accessible inside the technical housing and may cause serious injury or death if it's still running while cover is open.

1. Read this manual before operating the spreader.
2. Before operating, make sure all the equipment is securely mounted into place.
3. Check that there are no persons within the spreader spray area when starting and operating this spreader.
4. Do not exceed your vehicle total weight beyond payload limits.
5. Always turn off the spreader before cleaning, lubricating or unclogging material jams.
6. Never climb or ride on or in the spreader.
7. Ensure that you have fastened the spreader to the vehicle according to descriptions in this manual.
8. A spreader in need of repairs or maintenance should not be operated.
9. Before removing or replacing any electrical components, always disconnect the battery.
10. Do not keep gasoline or other flammable liquids on the truck bed while spreader is mounted on the truck bed.

WARNING
Always keep bystanders a minimum of 10 meters away when operating the spreader.

CAUTION
Empty and clean the hopper after each use. Unused spreading material left in hopper could freeze or solidify, causing the spreader to not work properly.

WARNING
Wait for auger and spinner to stop and lock out power before servicing the spreader.

NOTE
Use a good quality multi-purpose grease to lubricate grease fittings after each use.

Recommended vehicle requirements

This spreader is suitable for tractors and loaders with a minimum capacity of 800 kg

Noise

The noise caused by the running spreader does not exceed 70 dB

Personal safety

- To prevent accidents, secure long hair and do not wear jewellery or a necktie. Only wear tight-fitting clothing while working on your spreader or vehicle.
- Protect your eyes with safety goggles to prevent injury from battery acid, gasoline, dirt, and dust.
- Always handle solid and liquid materials carefully. Wear safety goggles, a mouth mask, gloves, and protective clothing to protect yourself from splattering materials.

Emergency stop

The emergency stop button is located below the protruding hopper area on the left side of the spreader. All spreader functions will immediately stop by pushing this button.

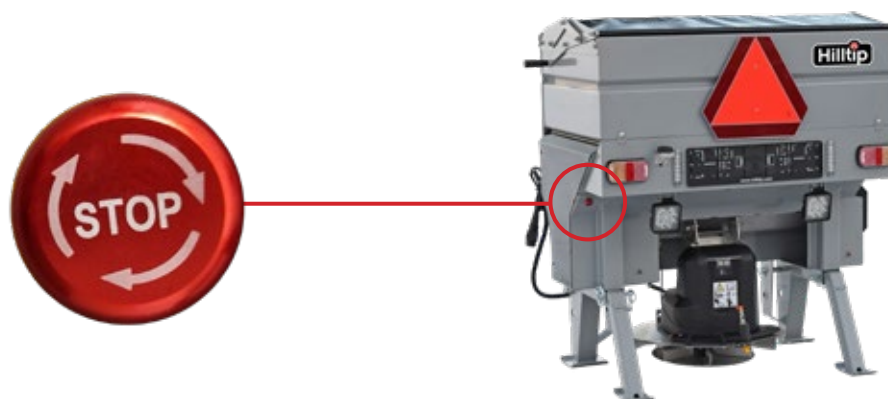

Warning and caution labels

Please become familiar with warning and caution labels on the spreader.

Warning - Handling of abrasive and chemical material can cause injury

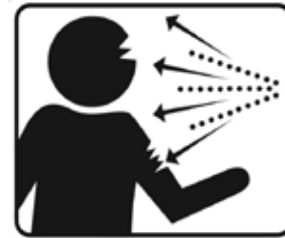

- Located on the chute

Warning - Keep away from spinner and spreader in motion. Stay clear of turning spinner. Moving parts can crush and cut



- Located on the chute

Warning - Disconnect power and wait for spinner and auger to stop completely before servicing, opening the cover to the technical housing or removing the top screen. The auger is fully accessible inside the technical housing and may cause serious injury or death if it's still running while cover is open.



Accessory cables

- Red** = Emergency stop (standard)
- Yellow** = Beacon light
- White** = LED worklight

Control placement

The controller should be mounted in a place where it can easily be reached and doesn't interfere with the access to vehicle controls or other equipment. Make sure that the spreader control panel doesn't block the vehicle airbag area. Protect the controller from water, dirt and dust.



Mounting the spreader

- Adjust the tractor's position so that the lower hitch arms are aligned with the lower attachment points on the spreader. Connect the hitch arms.
- Connect the electrical cable from the spreader to the tractor's power outlet. Ensure that the plug is securely in place.

NOTE! Check that the cables are not pinched or will not get pinched when you raise the 3-point hitch. Adjust them if necessary to ensure they are free and not at risk of being damaged during operation.

NOTE! The support legs must be folded up and locked when the spreader is in place.



- Cat 2
- Cat 1

Opening tarp cover



Grab the handle and pull it toward the rear of the spreader to open the tarp cover.

Rotate jammed auger manually

If the error code “Auger jammed” appears, the auger can be rotated manually to release any solidified material or rocks. Always turn off the spreader before servicing it. Use a 24 mm socket wrench or similar tool to turn the auger screw.

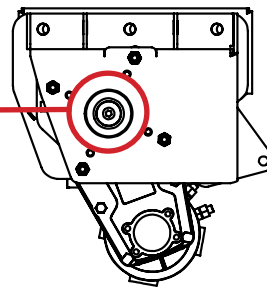
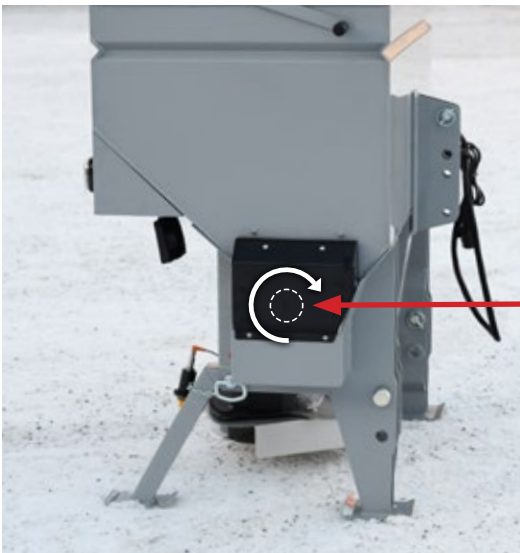

Remove the cover plate and use a socket wrench to rotate auger manually by turning it clockwise

Adjustable invert-V

The invert-V has adjustable side plates. Unscrew the bolts on both sides to adjust the plates up or down. When the plates are fully opened (adjusted upwards) more material is flowing down to the auger and give a more even material output. It is also possible to remove the adjustable plates if the used spreading material is not flowing down to auger and causing bridging above the auger.

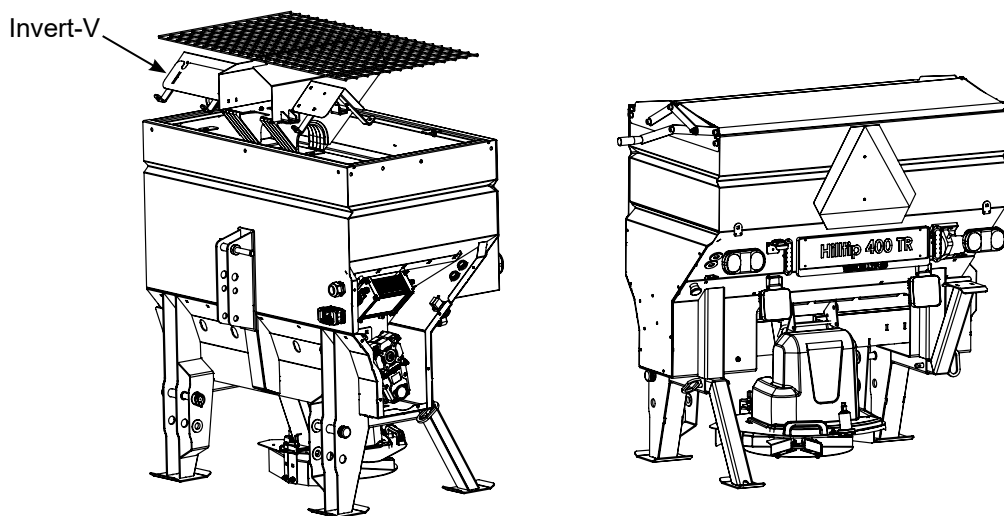
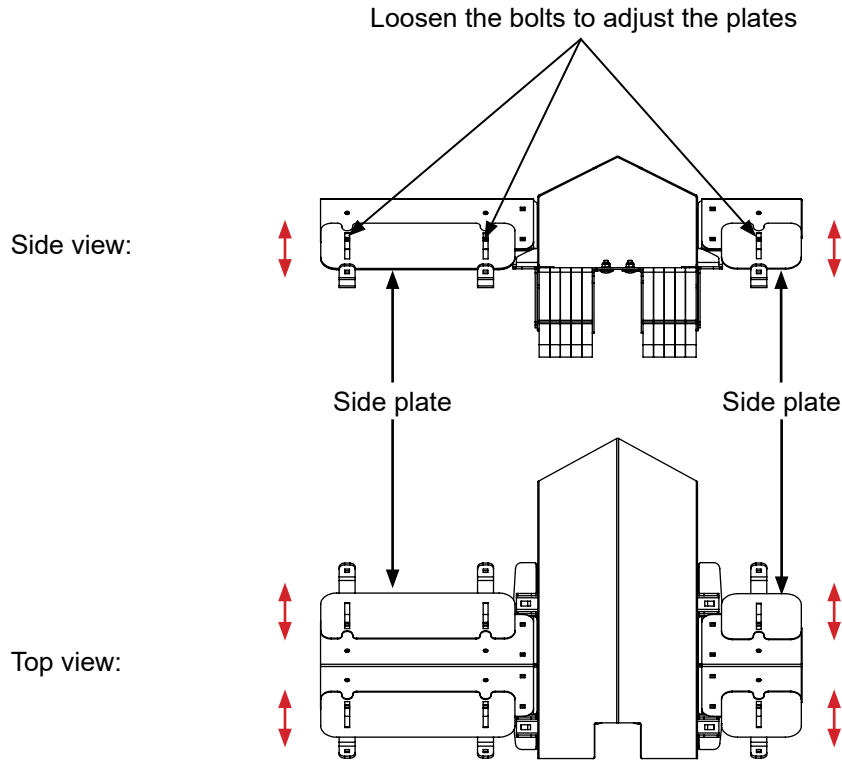

Spreading symmetry adjustment

The spreading pattern can be adjusted by rotating the spinner plate and by adjusting the chute baffle that controls how far in on the spreading disc the material falls down.

The spinner plate is rotated to the left or right by using the adjuster arm.

⊗ = material drop point

Spinner plate rotated left

Spinner plate center

Spinner plate rotated right

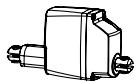
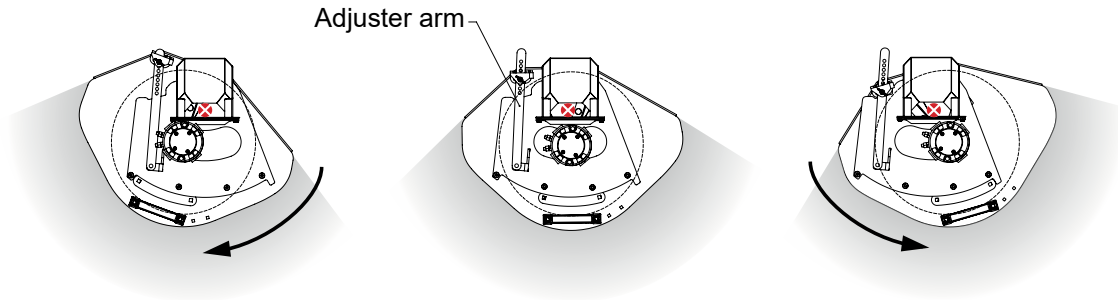

← Adjuster arm can be changed to the optional linear actuator for the optional electric chute adjustment, cabin control.

Electric spreading symmetry adjustment, cabin control (optional)

If the spreader is equipped with the optional electric chute adjustment the user adjusts the spreading symmetry from the controller inside the cab.

When the controller is in spreading mode, the icon on the left shows which position the chute is in. Push the round button so the selected area turns green and scroll the round button to adjust the chute. When scrolling the round button the spinner plate rotates to left or right.



The chute icon shows which position the chute is in.

End of material sensor (Optional)

Use the optional “End of Material” (EOM) sensor to detect when no material is coming out from the spreader.

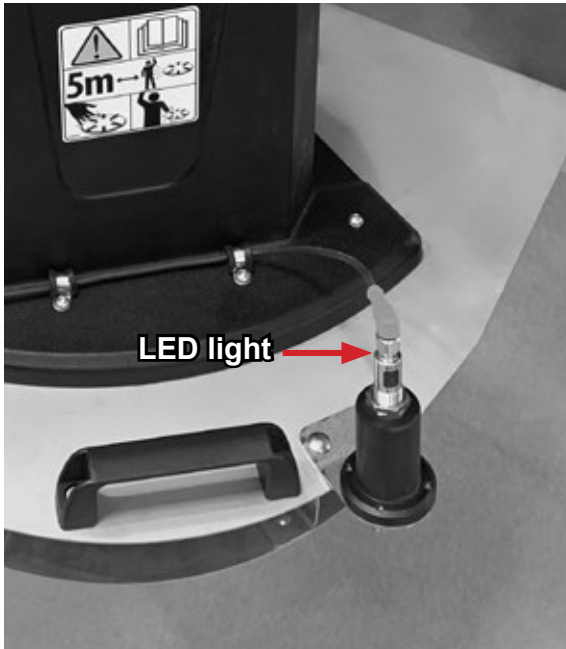

The EOM sensor's LED light lights orange when no material is coming out of the hopper and turns off material is coming out of the hopper.

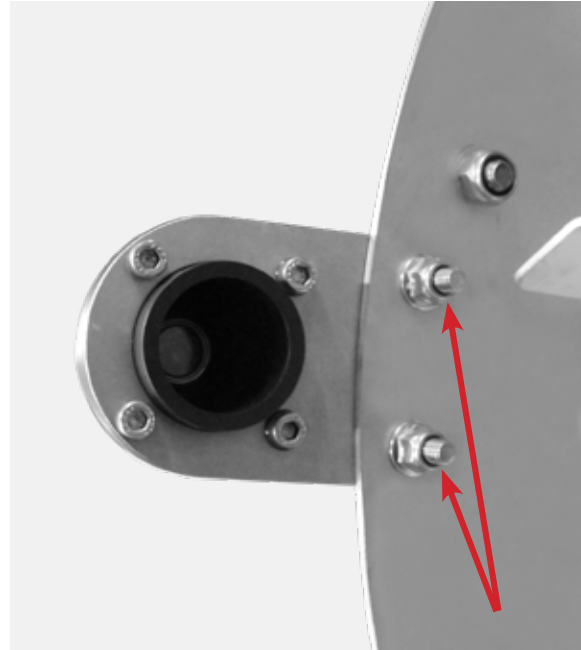

The sensor is bolted on the spinner frame.



Make sure you unscrew the cable from the sensor when removing the chute.



When there is no material coming out from the spinner, you see the message “spreader empty” on the controller. The message disappears when material is coming out from the spinner.

Calibration of end of material sensor

If EOM sensor is not working properly, do a new calibration.

How to calibrate:



1. Hold a piece of white paper at the same height as the spinner assembly, and press the upper button until the orange LED light starts flashing.

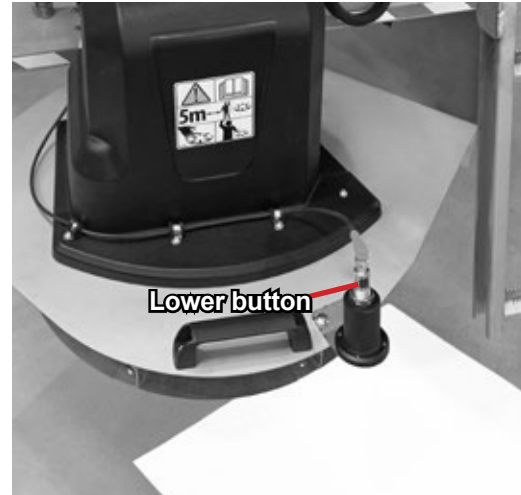

2. Place the white paper on the ground and press the lower button once. Now the led light is constant orange and the sensor is calibrated.

Electrical installation of end of material sensor

Connect the sensor cable to the spreader module:

- Blue - to ground terminal
- Black - to pin nr 29
- Brown - to pin nr 35

Average material weights

Material	Weight (kg/m ³)
Fine salt - dry	1201
Coarse salt - dry	721
Coarse sand - dry	1602
Coarse sand - wet	1922

Please see your local dealer for proper vehicle applications.



WARNING

Do not overload your vehicle beyond GVWR or GAWR, overloading could result in accident or damage.



CAUTION

These material weights are only guidelines, for more precise data, read and adhere to the manufacturer's ice-control material package labeling, including Material Safety Data sheet requirements.

Removing the spreader



NOTE

The hopper should always be emptied before removing the spreader.





NOTE

Always close hopper lid/deploy tarp to avoid moisture buildup. Do not let spreader sit idle with material in the hopper for a long time.

Maintaining the spreader

 **WARNING**
Power should always be shut off before and during service or maintenance of the spreader.

 **WARNING**
Never remove spreader with material in hopper

 **NOTE**
You must follow all the steps in these maintenance checklists for warranty to be valid.

 **CAUTION**

- Do not operate a damaged spreader or a spreader in need of maintenance
- Spreader should be emptied and cleaned after each use. Left over material could freeze or solidify in the hopper causing the spreader to not work properly.

Periodical maintenance checklist (check weekly in high-season)

Clean the hopper carefully inside and out with water. Avoid spraying water into bearings, motor and electrical connections.
Check that all screws and fasteners are tight enough. If you notice any missing or damaged fasteners or other parts, replace immediately.
Check that all installations and parts are still securely fastened to the spreader assembly.
Apply dielectric grease on all electrical connections.
Lubricate grease fittings with a good quality multipurpose grease.

Yearly maintenance checklist (e.g. before or after putting your spreader away for storage)

Clean the hopper carefully inside and out with water, before putting it in storage. Avoid spraying water into bearings, motor and electrical connections.
Clean and apply dielectric grease on all electrical plugs and connectors. Clean and install all dust caps before placing your spreader in storage
Lubricate grease fittings with a good quality multipurpose grease.
Check condition of bearings, replace if needed.
Cover the spreader with a tarp during storage, to protect it from sun fading and other weather conditions and circumstances.

IMPORTANT:

It is strongly recommended and of great importance that you regularly apply dielectric grease on all electrical connectors and protect them with caps when not in use to prevent corrosion. While cables are connected, also connect matching caps to protect them from dirt and dust.

**Storage**

Apply to these recommendations before placing your spreader in off-season storage to maintain it in a good condition.

- Cover your spreader using a tarp during storage periods
- Apply a protective compound such as dielectric grease on all electrical connectors and use caps for protection before storage.
- Disconnect and remove the control unit from your vehicle. Store it in a dry and cool place, and protect it from heat and moisture.
- Empty the hopper, remove all kinds of debris and clean the hopper from dirt before storage.
- Protect the hopper from excessive heat during storage periods.

Greasing points

Grease fittings should be lubricated approximately every 20 operating hours.

Auger greasing points



Spinner greasing point



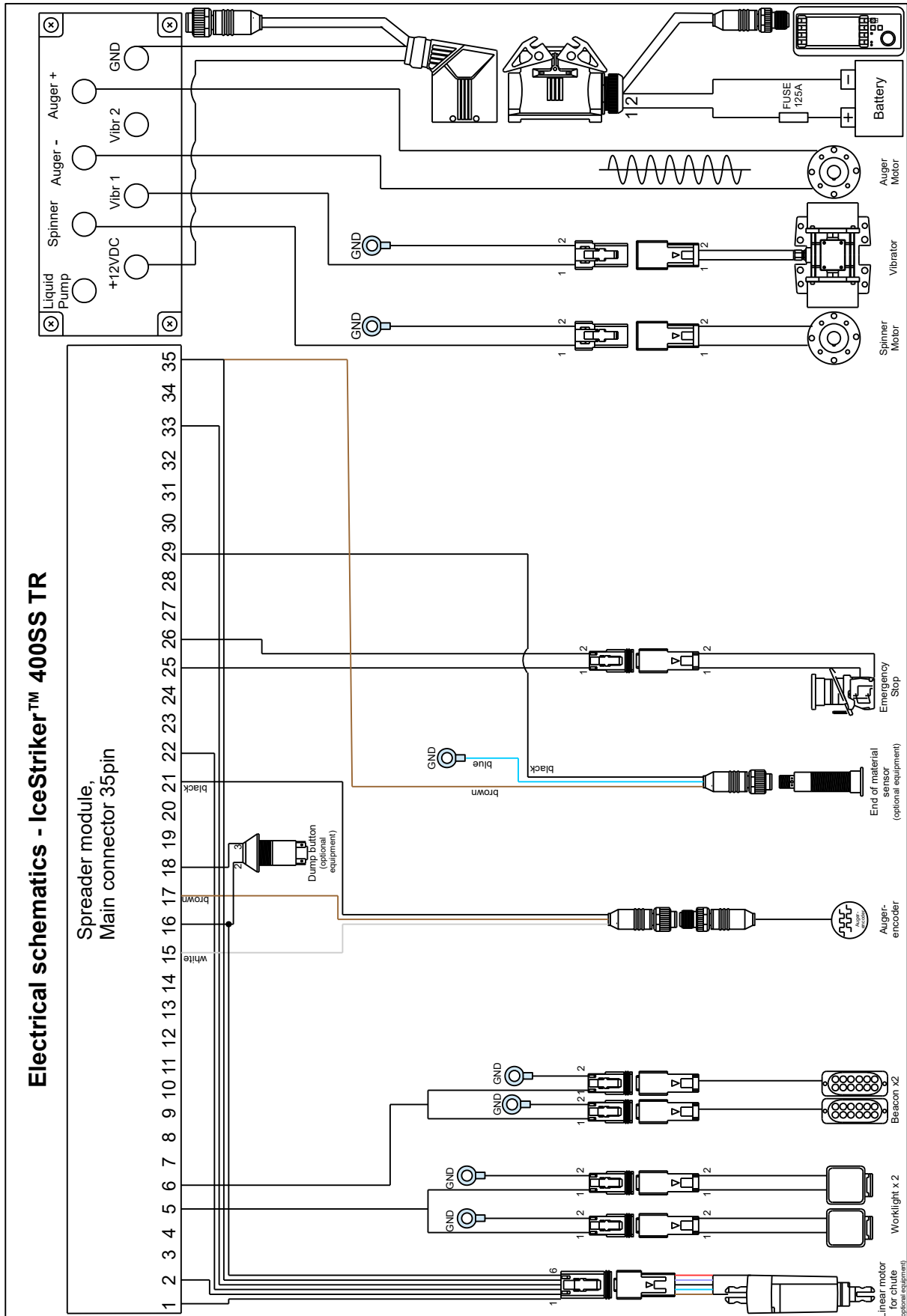

Warranty information

This warranty replaces all previous warranties

Warranty

Thank you for your interest in the products and services of Oy Hilltip Ab. This Limited Warranty applies to snowplows, spreaders, sweepers and other products and parts (from now on referred to as the "Product") purchased from Hilltip or an authorized dealer.

What does this limited warranty cover?

This Limited Warranty covers any defects in material or workmanship under normal use during the Warranty Period.

During the Warranty Period, Hilltip, or an authorized dealer will repair or replace, at no charge, products or parts of a product that proves defective because of improper material or workmanship, under normal use and maintenance.

How long does the coverage last?

The Warranty Period for the product purchased from Hilltip, or an authorized dealer is two (2) years from the date of purchase. The warranty period for a replacement part is one (1) year from the date of replacement or repair.

How to obtain warranty on your product?

Make sure your dealer has registered your product. In order to obtain service under this warranty the product must be registered with the end user's contact details (name, address, e-mail address and phone number).

What does this limited warranty not cover?

- Improperly installed parts.
- Damage caused by usage that is not in accordance with product instructions.
- Modification of the product, and/or the vehicle, is entirely at the purchaser's risk.
- This warranty does not include compensation for the drive to the service spot.
- Any damage in transit will be the responsibility of the carrier or at the risk of the purchaser.
- Hilltip will not provide replacement equipment or cover rental costs while your equipment is out of service.

This Limited Warranty does not cover any problem that is caused by:

- Misuse, neglect, accident, improper installation, maintenance or storage, or repair or alternation by anyone except Hilltip or an authorized dealer.

What do you have to do?

To obtain warranty service, you must first contact us or your authorized dealer. The purchaser must notify Hilltip or an authorized dealer within ten (10) days after any defect in the product becomes known during the warranty period.

What will we do to correct problems?

Hilltip, or an authorized dealer will repair or replace the part at no charge using either new or refurbished replacement parts.



DECLARATION OF CONFORMITY

Manufacturer's & Assambler's Name: **Oy Hilltip Ab**

Manufacturer's & Assambler's Address: **Pukkisaarentie 6, FIN-68600 Pietarsaari, Finland**

Equipment Description: Salt, Sand and Fertilizing Spreader, 400 liter

Equipment Model Designation: Hilltip IceStriker™ 400SS TR

Equipment applications: Tractors and loaders

The equipments specified above are manufactured, where applicable, in conformity with provisions of the normative document according to the following directives and standards, in addition to relevant Road Traffic Regulations in European countries:

- 2006/42/EC
- EN 15597-1
- ECE R10

I, the undersigned, hereby declare that the equipments specified above, that have been assambled by Oy Hilltip Ab, conforms to the above directives and standards

Pietarsaari, 14 April 2025

Signature:

Printed Name: Tom Mäenpää

Title: CEO

Installer's Name:

Installer's Address:

Type:

Serial number:

Year of installation:

I, the undersigned, hereby declare that the equipment installation to the vehicle specified above conforms to the directive 2006/42/EC and relevant Road Traffic Regulations.

DATE:

Signature:

Printed:

Title:



Oy Hilltip Ab
Pukkisaarentie 6
FIN-68600 Pietarsaari
Finland

www.hilltip.com
info@hilltip.com