

09 December 2025

Version 1.13



Ice **STRIKER™**



OWNER'S MANUAL

900-7000 L POLY ELECTRIC MODULAR SPREADER

This manual replaces all editions with an earlier date.

GENERAL INFORMATION	3
Spreader parts	3
Technical information	4
SAFETY INFORMATION	7
Safety definitions	7
Safety precautions	7
Recommended vehicle requirements	8
Noise	8
Personal safety	8
Emergency stop	8
Warning and caution labels	9
INSTALLATION AND OPERATION	10
Accessory cables	10
Control placement	10
Mounting the spreader	10
Opening tarp cover	11
Rotate jammed auger manually	11
Adjustable invert-V	12
Spreading symmetry adjustment	13
End of material sensor	15
Calibration of end of material sensor	16
Electrical installation of end of material sensor	16
LOADING	17
Average material weights	17
REMOVING THE SPREADER	18
Removing the spreader	18
MAINTENANCE	19
Maintaining the spreader	19
Tighten all bolts that hold the modules together	20
Chain tension adjustment	21
Storage	22
Optional liquid system	22
Greasing points	23
Auger greasing points	23
Conveyor greasing points	23
FLUID SCHEMATICS	24
ELECTRICAL SCHEMATIC	25
WARRANTY INFORMATION	27
CERTIFICATE OF CONFORMITY	28
PRODUCT EOL	29

CAUTION

Read this manual before installing or operating the spreader

Spreader parts



IceStriker™ 900 AM



IceStriker™ 3000 AM/CM



IceStriker™ 4000 AM/CM



IceStriker™ 5000 CM

Technical information 900-1250 AM/AML

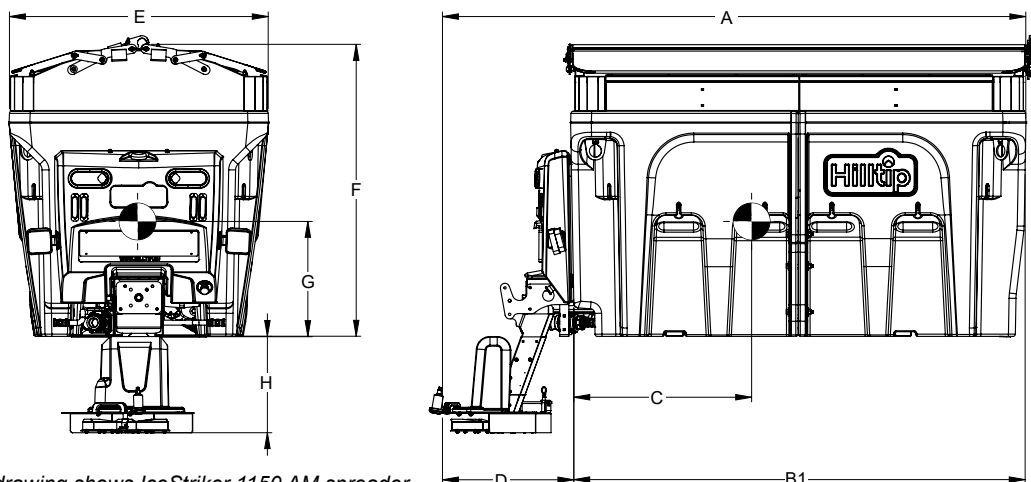

The drawing shows IceStriker 1150 AM spreader

Key	Description	900 AM	1150 AM	1250 AML
A	Total length	260 cm	260 cm	300 cm
B1	Maximum external hopper length	190 cm	190 cm	230 cm
B2**	Maximum external hopper length + extended auger	230 cm	230 cm	NA
C	Distance from the centre of gravity to the rear part of the hopper (empty)	740 mm	750 mm	950 mm
D	Total length of spreading group (disc + chute)	580-640* mm		
E	Maximum external width (with tarp mounted)	114 cm	114 cm	114 cm
F	Total height of the hopper from the loading surface of the carrying vehicle	115 cm	130 cm	115 cm
G	Height of the centre of gravity from the loading surface of the carrying vehicle (empty)	390 mm	400 mm	415 mm
H	Distance between spreading disc and loading surface of the carrying vehicle	Standard chute: 425 mm		

* Total length of spreading group with extended auger, ** Not shown

Description	900 AM	1150 AM	1250 AML
Hopper volume, struck	850 l	1100 l	1180 l
Hopper volume, rounded	900 l	1150 l	1250 l
Liquid tank capacity	450 l	430 l	530 l
Empty spreader weight	225 kg	245 kg	270 kg
Full loaded spreader solid material, <i>struck volume</i>	1415 kg	1785 kg	1922 kg
Full loaded spreader solid material, <i>rounded volume</i>	1485 kg	1855 kg	2020 kg
Full loaded spreader solid material, <i>struck volume</i> , and liquid material full tank	1910 kg	2280 kg	2505 kg
Full loaded spreader solid material, <i>rounded volume</i> , and liquid material full tank	1980 kg	2350 kg	2603 kg

These numbers are only guidelines, and based on solid materials with a density of 1400 kg/m³, and brine liquid with a density of 1100 kg/m³.

Specifications are subject to change without notice. We do not take any responsibility in any direct or indirect damages or warranty cases concerning the values above.

Technical information 1600-2600 CM

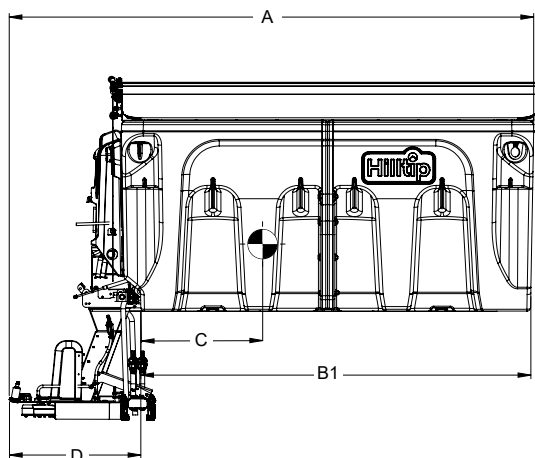
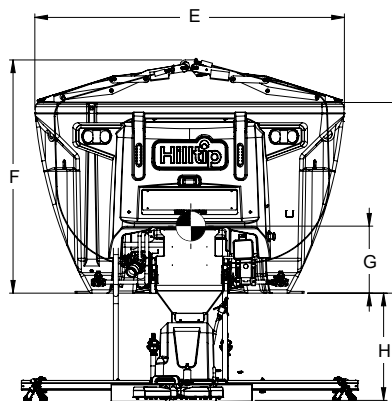

The drawing shows IceStriker 1600 CM spreader

Key	Description	1600 CM	2100 CM	2600 CM
A	Total length	290 cm	290 cm	290 cm
B1	Maximum external hopper length	215 cm	215 cm	215 cm
B2**	Maximum external hopper length + extended chain	275 cm	275 cm	275 cm
C	Distance from the centre of gravity to the rear part of the hopper (empty)	68 cm	74 cm	80 cm
D	Total length of spreading group (disc + chute)	730-790* mm		
E	Maximum external width (with tarp mounted)	170 cm		
F	Total height of the hopper from the loading surface of the carrying vehicle	130 cm	142 cm	155 cm
G	Height of the centre of gravity from the loading surface of the carrying vehicle (empty)	37 cm	43 cm	50 cm
H	Distance between spreading disc and loading surface of the carrying vehicle	Standard chute: 590-710 Extended chute (+25 cm): 840-960 Extended chute (+55 cm): 1140-1260		

* Total length of spreading group with extended chain, ** Not shown

Description	1600 CM	2100 CM	2600 CM
Hopper volume, struck	1600 l	2100 l	2600 l
Hopper volume, rounded	1800 l	2400 l	2900 l
Liquid tank capacity	900 l	900 l	900 l
Empty spreader weight	405 kg	440 kg	465 kg
Full loaded spreader solid material, <i>struck volume</i>	2645 kg	3380 kg	4105 kg
Full loaded spreader solid material, <i>rounded volume</i>	2925 kg	3800 kg	4525 kg
Full loaded spreader solid material, <i>struck volume</i> , and liquid material full tank	3635 kg	4370 kg	5095 kg
Full loaded spreader solid material, <i>rounded volume</i> , and liquid material full tank	3915 kg	4790 kg	5515 kg

These numbers are only guidelines, and based on solid materials with a density of 1400 kg/m³, and brine liquid with a density of 1100 kg/m³.

Specifications are subject to change without notice. We do not take any responsibility in any direct or indirect damages or warranty cases concerning the values above.

Technical information 3000,4000 AM/CM and 5000-7000 CM

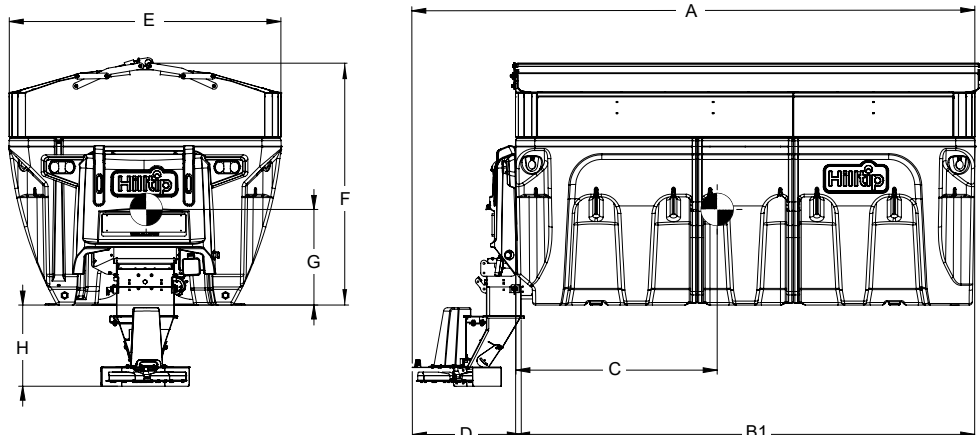

The drawing shows IceStriker 4000 AM spreader

Key	Description	3000 AM/CM	4000 AM/CM	5000 CM	6000 CM	7000CM
A	Total length	360cm	360 cm	410 cm	410 cm	460 cm
B1	Maximum external hopper length	290 cm	290 cm	350 cm	350 cm	410 cm
B2**	Maximum external hopper length + extended auger/chain	350 cm	350 cm	410 cm	410 cm	470 cm
C	Distance from the centre of gravity to the rear part of the hopper (empty)	115 cm	125 cm	140 cm	150 cm	165 cm
D	Total length of spreading group (disc + chute)	680-740* mm				
E	Maximum external width (with tarp mounted)	170 cm	170 cm	170 cm	170 cm	170 cm
F	Total height of the hopper from the loading surface of the carrying vehicle	130 cm	155 cm	155 cm	165 cm	155 cm
G	Height of the centre of gravity from the loading surface of the carrying vehicle (empty)	50 cm	60 cm	75 cm	85 cm	100 cm
H	Distance between spreading disc and loading surface of the carrying vehicle	Standard chute: 590-710 Extended chute (+25 cm): 840-960 Extended chute (+55 cm): 1140-1260				

* Total length of spreading group with extended auger/chain, ** Not shown

Description	3000 AM/CM	4000 AM/CM	5000 CM	6000 CM	7000 CM
Hopper volume, struck	2600 l	3200 l	4200 l	5200 l	6200 l
Hopper volume, rounded	3000 l	4000 l	5000 l	6000 l	7000 l
Liquid tank capacity	1000 l	1000 l	1200 l	1200 l	1400 l
Empty spreader weight	480 kg	505 kg	750 kg	850 kg	950 kg
Full loaded spreader solid material, <i>struck volume</i>	4120 kg	4985 kg	6630 kg	8130 kg	9630 kg
Full loaded spreader solid material, <i>rounded volume</i>	4680 kg	6105 kg	7600 kg	9250 kg	10750 kg
Full loaded spreader solid material, <i>struck volume</i> , and liquid material full tank	5220 kg	6085 kg	7750kg	9450 kg	11170 kg
Full loaded spreader solid material, <i>rounded volume</i> , and liquid material full tank	5780 kg	7205 kg	9070 kg	10570 kg	12290 kg

These numbers are only guidelines, and based on solid materials with a density of 1400 kg/m³, and brine liquid with a density of 1100 kg/m³.

Specifications are subject to change without notice. We do not take any responsibility in any direct or indirect damages or warranty cases concerning the values above.

Safety definitions



WARNING

Implies a potentially hazardous situation that, if not avoided, could result in death or serious personal injury.



NOTE

Implies a situation or action that can lead to damage to your spreader and vehicle or other property. Other useful information can also be described.



CAUTION

Implies a potentially hazardous situation that, if not avoided, may result in minor or moderate injury. It may also be used to alert against unsafe practices.

Safety precautions

Incorrect installation and operation can lead to serious personal injury and/or damage your equipment and property. Note and ensure that you understand this manual and all the labels before installing, operating or making adjustments to the spreader.



WARNING

Observe these safety precautions before, during and after operating the spreader. You can prevent injury to persons and damage to the spreader by following these precautions.



WARNING

Warning - Disconnect power and wait for spinner and auger to stop completely before servicing, opening the cover to the technical housing or removing the top screen. The auger is fully accessible inside the technical housing and may cause serious injury or death if it's still running while cover is open.

1. Read this manual before operating the spreader.
2. Before operating, make sure all the equipment is securely mounted into place.
3. Check that there are no persons within the spreader spray area when starting and operating this spreader.
4. Do not exceed your vehicle total weight beyond payload limits.
5. Always turn off the spreader before cleaning, lubricating or unclogging material jams.
6. Never climb or ride on or in the spreader.
7. Ensure that you have fastened the spreader to the vehicle according to descriptions in this manual.
8. A spreader in need of repairs or maintenance should not be operated.
9. Before removing or replacing any electrical components, always disconnect the battery.
10. Do not keep gasoline or other flammable liquids on the truck bed while spreader is mounted on the truck bed.

WARNING
Always keep bystanders a minimum of 10 meters away when operating the spreader.

CAUTION
Empty and clean the hopper after each use. Unused spreading material left in hopper could freeze or solidify, causing the spreader to not work properly.

WARNING
Wait for auger and spinner to stop and lock out power before servicing the spreader.

NOTE
Use a good quality multi-purpose grease to lubricate grease fittings after each use.

Recommended vehicle requirements

This spreader is suitable for trucks and trailers with a minimum capacity of 2000 kg

Noise

The noise caused by the running spreader does not exceed 70 dB

Personal safety

- To prevent accidents, secure long hair and do not wear jewelry or a necktie. Only wear tight-fitting clothes while working on your spreader or vehicle.
- Protect your eyes with safety goggles to avoid damage from battery acid, gasoline, dirt and dust.
- Always handle the solid and liquid materials carefully. Wear safety goggles, mouth mask, gloves and protective close to protect yourself from spattering material.

Emergency stop

The spreader has an emergency stop button located at the right side of the chute. All spreader functions will immediately stop by pushing this button.

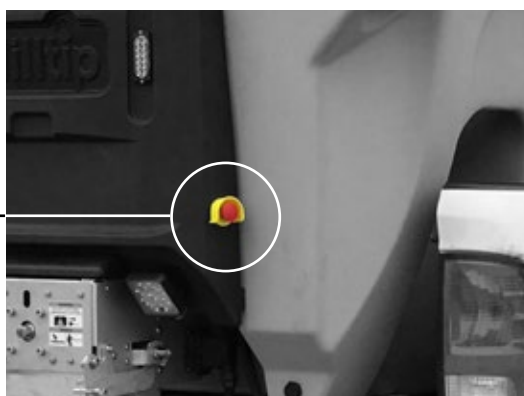

Warning and caution labels

Please become familiar with warning and caution labels on the spreader.

Warning - Handling of abrasive and chemical material can cause injury



- Located on the chute

Warning - Keep away from spinner and spreader in motion. Stay clear of turning spinner. Moving parts can crush and cut



- Located on the chute

Warning - Disconnect power and wait for spinner and auger to stop completely before servicing, opening the cover to the technical housing or removing the top screen. The auger is fully accessible inside the technical housing and may cause serious injury or death if it's still running while cover is open.



Accessory cables

- Red** = Emergency stop (standard)
- Black (big connector)** = Water pump
- Black (small connector)** = Water pump
- Yellow** = Beacon light
- White** = LED worklight

Control placement

The controller should be mounted in a place where it can easily be reached and doesn't interfere with the access to vehicle controls or other equipment. Make sure that the spreader control panel doesn't block the vehicle airbag area. Protect the controller from water, dirt and dust.



Mounting the spreader

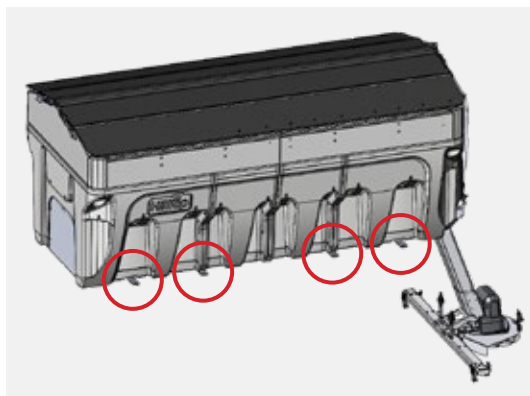

There are fastening hooks on each side of the spreader bottom. Use these fastening points to bolt the spreader to the vehicle. The number of fastening hooks vary depending on the size of the spreader.



There are built-in tie-down loops on each corner of the hopper. Use these fastening points to secure the spreader to the vehicle by using tensioning straps.



WARNING

The spreader is required to be fastened with tensioning straps in all four corners and attached to the vehicle bed with bolts.



Ensure that the spreader is fully supported across the entire area beneath the poly hopper.

Opening tarp cover



1. Pull left wire to open hook.



2. Pull right wire to open the right side of the tarp cover.



3. Pull left wire to open the left side of the tarp cover.

Rotate jammed auger manually

If the error code “Auger jammed” appears, the auger can be rotated manually to release any solidified material or rocks. Always turn off the spreader before servicing it. Use a 24 mm socket wrench or similar tool to turn the auger screw.

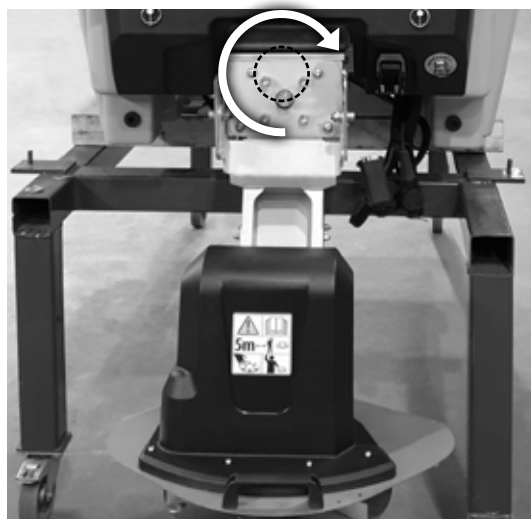

Use a socket wrench to rotate auger manually by turning it clockwise

Adjustable invert-V

The invert-V has adjustable side plates. Unscrew the bolts on both sides to adjust the plates up or down. When the plates are fully opened (adjusted upwards) more material is flowing down to the auger and give a more even material output. It is also possible to remove the adjustable plates if the used spreading material is not flowing down to auger and causing bridging above the auger.

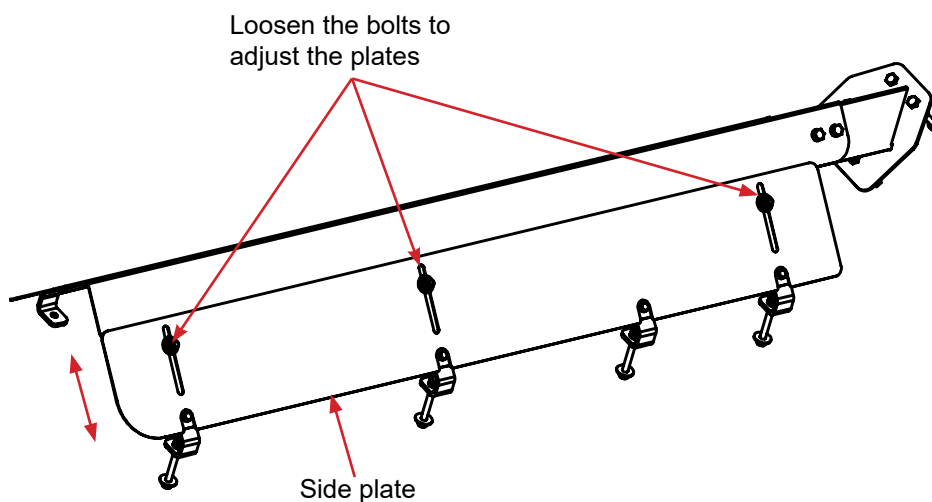
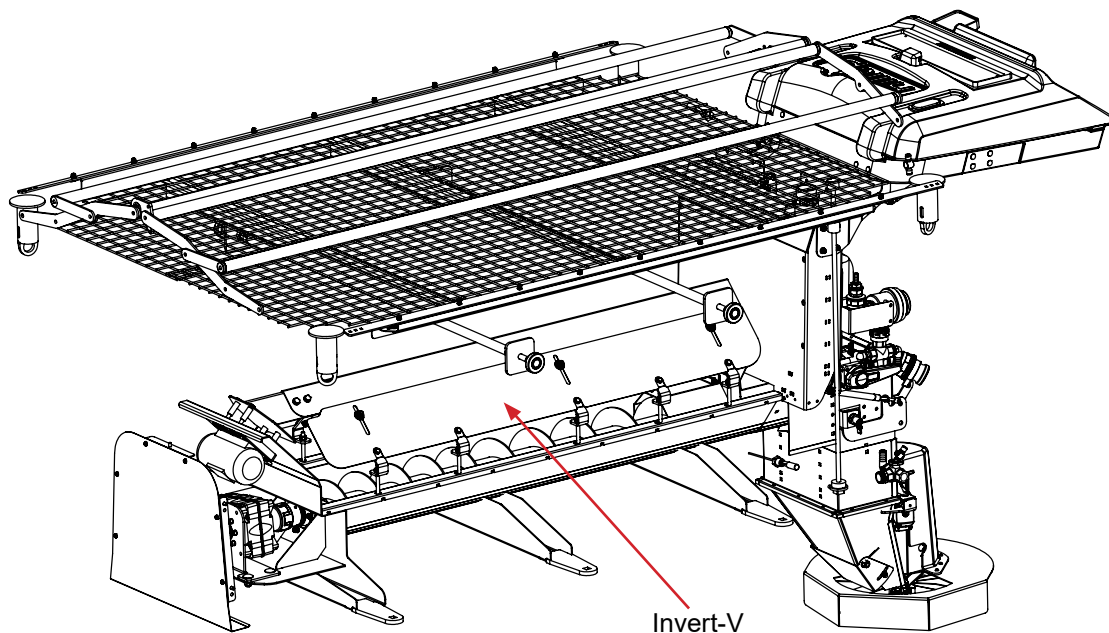

Spreading symmetry adjustment

The spreading pattern can be adjusted by rotating the spinner plate and by adjusting the chute baffle that controls how far in on the spreading disc the material falls down.

The spinner plate is rotated to the left or right by using the adjuster arm.

⊗ = material drop point

Spinner plate rotated left

Spinner plate center

Spinner plate rotated right

900 AM-
1250 AML

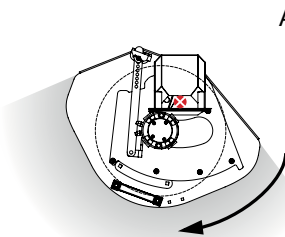

Adjuster arm

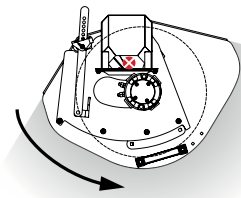
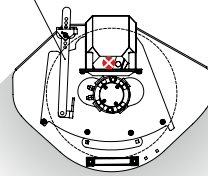

3000 AM/CM-
5000 CM

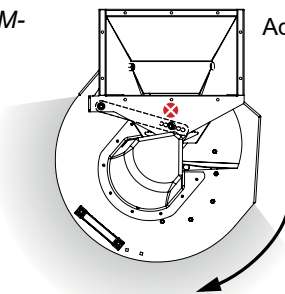

Adjuster arm

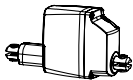
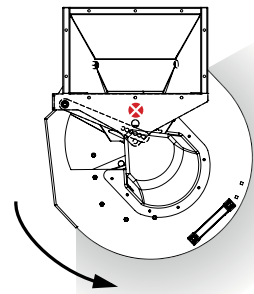
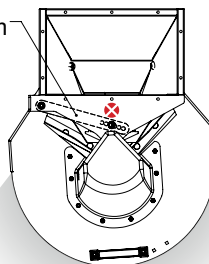

← Adjuster arm can be changed to the optional linear actuator for the optional electric chute adjustment, cabin control.

Electric spreading symmetry adjustment, cabin control (optional)

If the spreader is equipped with the optional electric chute adjustment the user adjusts the spreading symmetry from the controller inside the cab.

When the controller is in spreading mode, the icon on the left shows which position the chute is in. Push the round button so the selected area turns green and scroll the round button to adjust the chute. When scrolling the round button the spinner plate rotates to left or right.



The chute icon shows which position the chute is in.

Loosen the bolts on both sides of the chute to adjust the chute baffle that controls how far in on the spreading disc the material falls down. **Note!** Applies only to 3000-5000 AM/CM spreaders with the non-current chute model (produced before May 2022).

When the chute baffle is fully closed (image 1) the spreading material falls down closer to the center of the disc and the material tends to spread more to the left (drivers side).

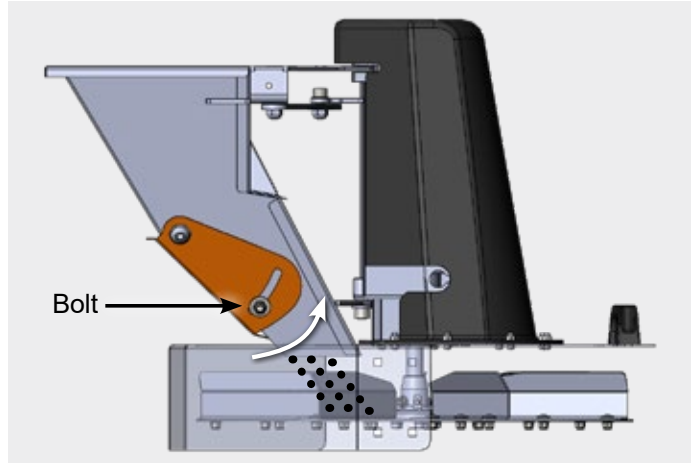

Image 1. The spreading material falls down closer to the center of the disc.

When the chute baffle is fully opened (image 2) the spreading material falls down further out on the disk and the material tends to spread more to the right (passengers side).

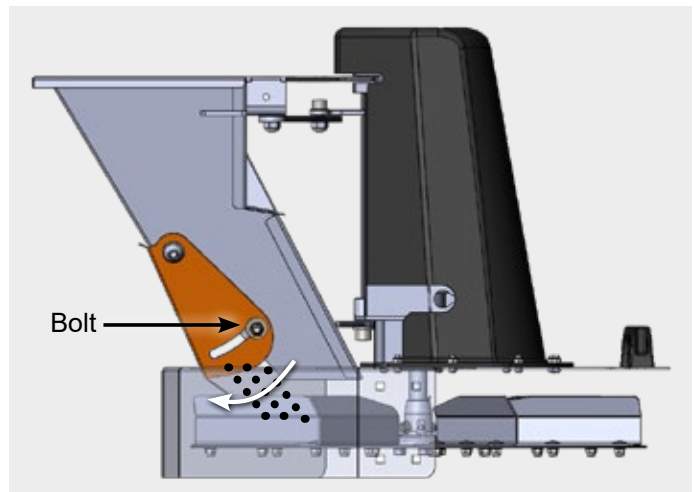

Image 2. The spreading material falls down further out on the disk.

NOTE! The spreading pattern is also affected by the speed of the spinner and the type of spreading material used.

End of material sensor (Optional)

Use the optional “End of Material” (EOM) sensor to detect when no material is coming out from the spreader.



The EOM sensor's LED light lights orange when no material is coming out of the hopper and turns off material is coming out of the hopper.

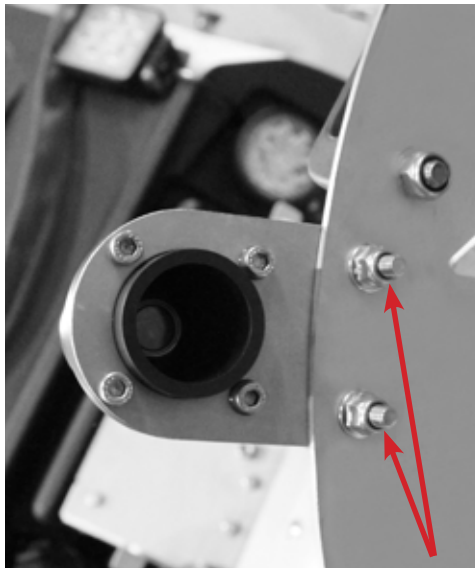

The sensor is bolted on the spinner frame.

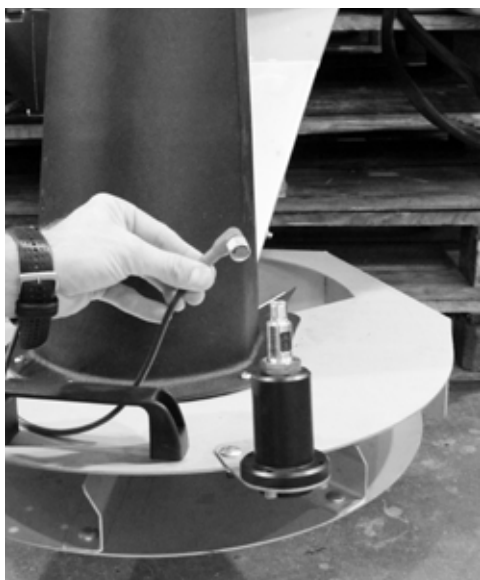

Make sure you unscrew the cable from the sensor when removing the chute.



When there is no material coming out from the spinner, you see the message “spreader empty” on the controller. The message disappears when material is coming out from the spinner.

Calibration of end of material sensor

If EOM sensor is not working properly, do a new calibration.

How to calibrate:

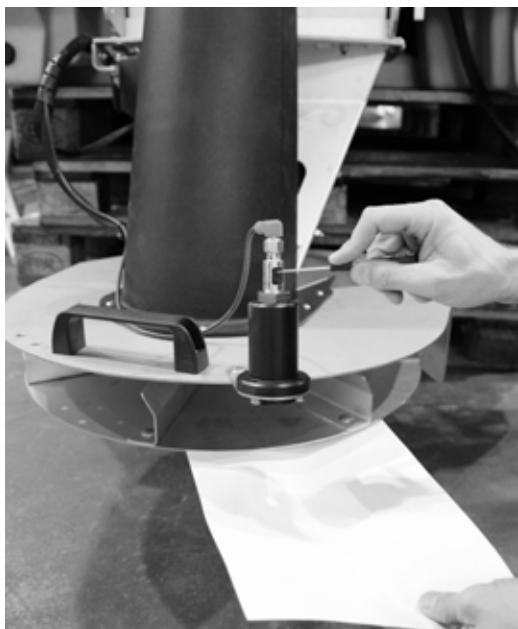

1. Hold a piece of white paper at the same height as the spinner assembly and press the upper button until the orange led light starts to flash.

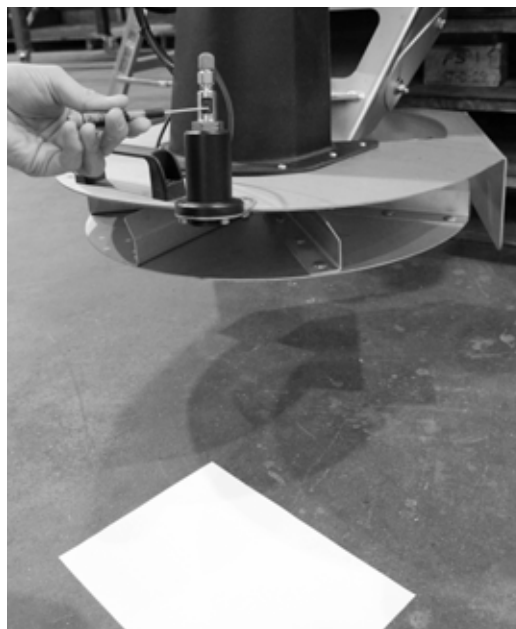

2. Put the white paper on the ground and press the lower button once. Now the led light is constant orange and the sensor is calibrated.

Electrical installation of end of material sensor

Connect the sensor cable to the spreader module:

Blue - to ground terminal
Black - to pin nr 29
Brown - to pin nr 35

Average material weights

Material	Weight (kg/m ³)
Fine salt - dry	1201
Coarse salt - dry	721
Coarse sand - dry	1602
Coarse sand - wet	1922

Please see your local dealer for proper vehicle applications.



WARNING

Do not overload your vehicle beyond GVWR or GAWR, overloading could result in accident or damage.



CAUTION

These material weights are only guidelines, for more precise data, read and adhere to the manufacturer's ice-control material package labeling, including Material Safety Data sheet requirements.

Removing the spreader

**CAUTION**

Remove the spreader with a forklift with minimum 1500 kg lifting capacity. Make sure bystanders keep a safe distance.

**NOTE**

The hopper should always be emptied before removing the spreader.

**NOTE**

Always close hopper lid/deploy tarp to avoid moisture buildup. Do not let spreader sit idle with material in the hopper for a long time.

Maintaining the spreader

 **WARNING**
Power should always be shut off before and during service or maintenance of the spreader.

 **WARNING**
Never remove spreader with material in hopper

 **NOTE**
You must follow all the steps in these maintenance checklists for warranty to be valid.

 **CAUTION**

- Do not operate a damaged spreader or a spreader in need of maintenance
- Spreader should be emptied and cleaned after each use. Left over material could freeze or solidify in the hopper causing the spreader to not work properly.

Daily checklist

Empty the conveyor bottom plate.

Periodical maintenance checklist (check weekly in high-season)

Clean the hopper carefully inside and out with water. Avoid spraying water into bearings, motor and electrical connections.

Check that all screws and fasteners are tight enough. If you notice any missing or damaged fasteners or other parts, replace immediately.

Check that all installations and parts are still securely fastened to the spreader assembly.

Apply dielectric grease on all electrical connections.

Lubricate grease fittings with a good quality multipurpose grease.

Yearly maintenance checklist (e.g. before or after putting your spreader away for storage)

Clean the hopper carefully inside and out with water, before putting it in storage. Avoid spraying water into bearings, motor and electrical connections.

Clean and apply dielectric grease on all electrical plugs and connectors. Clean and install all dust caps before placing your spreader in storage

Lubricate grease fittings with a good quality multipurpose grease.

Check condition of bearings, replace if needed.

Cover the spreader with a tarp during storage, to protect it from sun fading and other weather conditions and circumstances.

Tighten all bolts that hold the modules together

All bolts that hold the modules together should be tightened seasonally. If the bolts have not been tightened regularly, the seal may come loose. If the seal has come loose, it must be put in place and after that the bolts should be tightened (25-30 Nm).

1. Place the spreader so that you can access the bolts under the spreader.
2. If the seal has come loose. Loosen the bolts and put the loose seal in place using e.g. a rubber mallet.
3. Tighten all bolts between 25 and 30 Nm. See the picture below where the bolts are located.

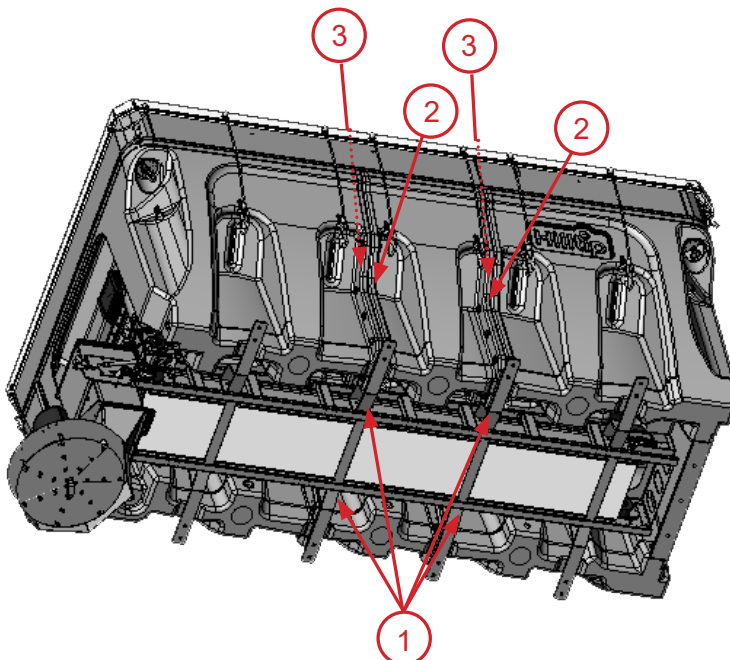

The image shows where the bolts to be tightened are located

Chain tension adjustment

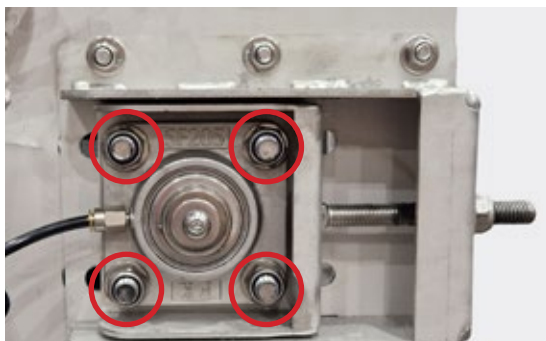

1. Loosen the bearing nuts before adjusting the chain tension.

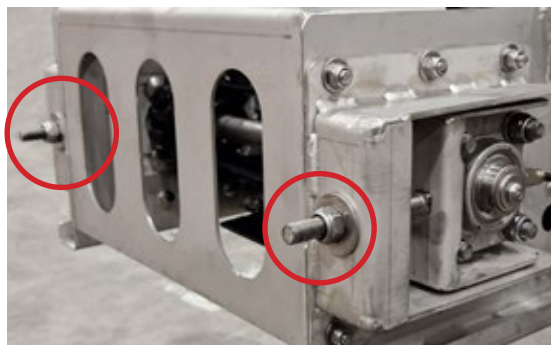

2. Tighten the nuts to adjust the chain tension.

3. Retighten the bearing nuts.

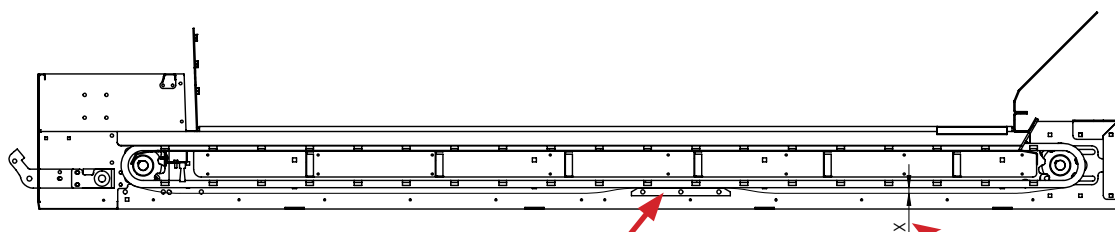
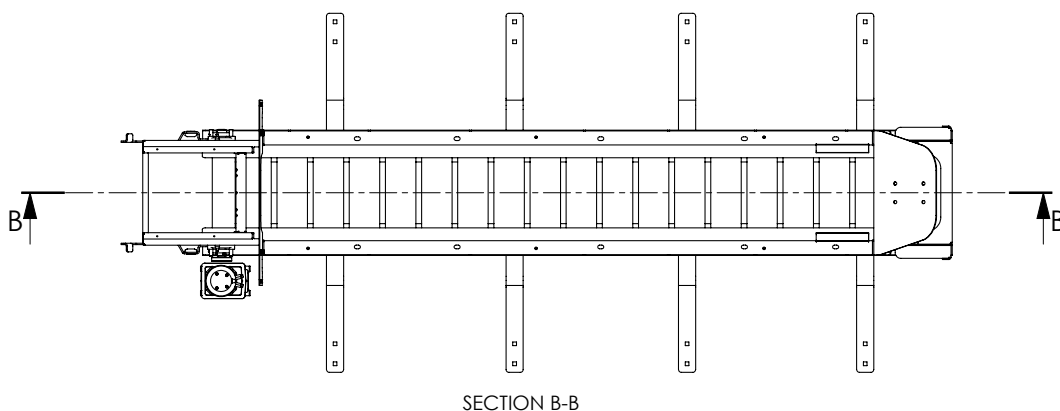

Inspect chain plastic guides (H40448) for excessive wear and replace if necessary.

Chain tension should be adjusted so that slack is between **3–15 mm**.

IMPORTANT:

It is strongly recommended and of great importance that you regularly apply dielectric grease on all electrical connectors and protect them with caps when not in use to prevent corrosion. While cables are connected, also connect matching caps to protect them from dirt and dust.

**Storage**

Apply to these recommendations before placing your spreader in off-season storage to maintain it in a good condition.

- Cover your spreader using a tarp during storage periods
- Apply a protective compound such as dielectric grease on all electrical connectors and use caps for protection before storage.
- Disconnect and remove the control unit from your vehicle. Store it in a dry and cool place, and protect it from heat and moisture.
- Empty the hopper, remove all kinds of debris and clean the hopper from dirt before storage.
- Protect the hopper from excessive heat during storage periods.

Optional liquid system

The liquid tank should always be emptied after each use (turn the red handle). Also empty the filter. If liquids are left in the tank for an extended period of time, it may freeze and cause damage to your spreader. Also make sure to clean the filter regularly.

Greasing points

Grease fittings should be lubricated approximately every 20 operating hours.

Auger greasing points

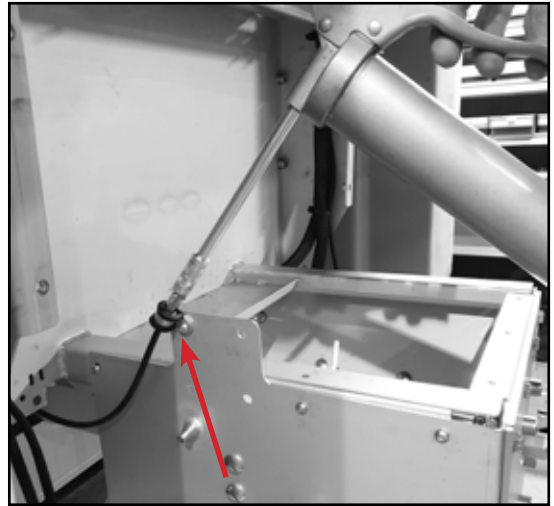
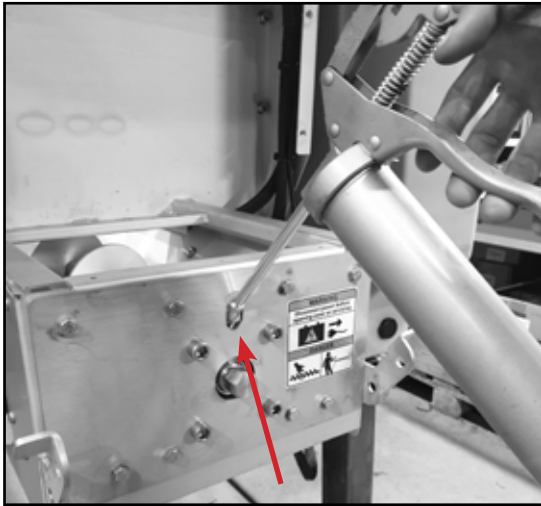

Conveyor greasing points

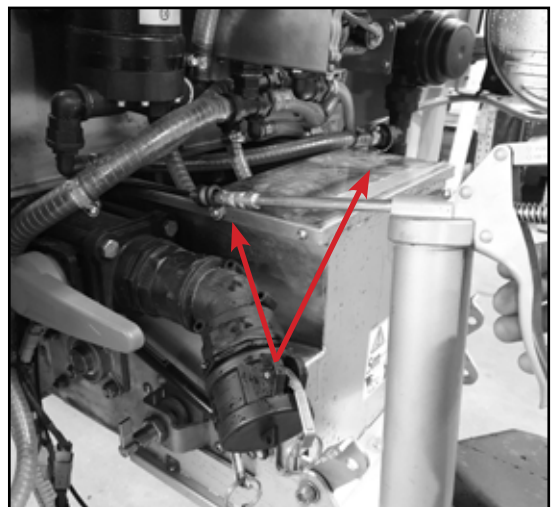
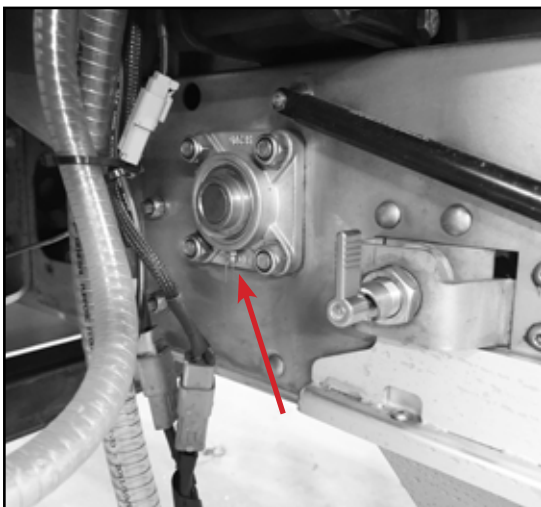

FLUID SCHEMATICS

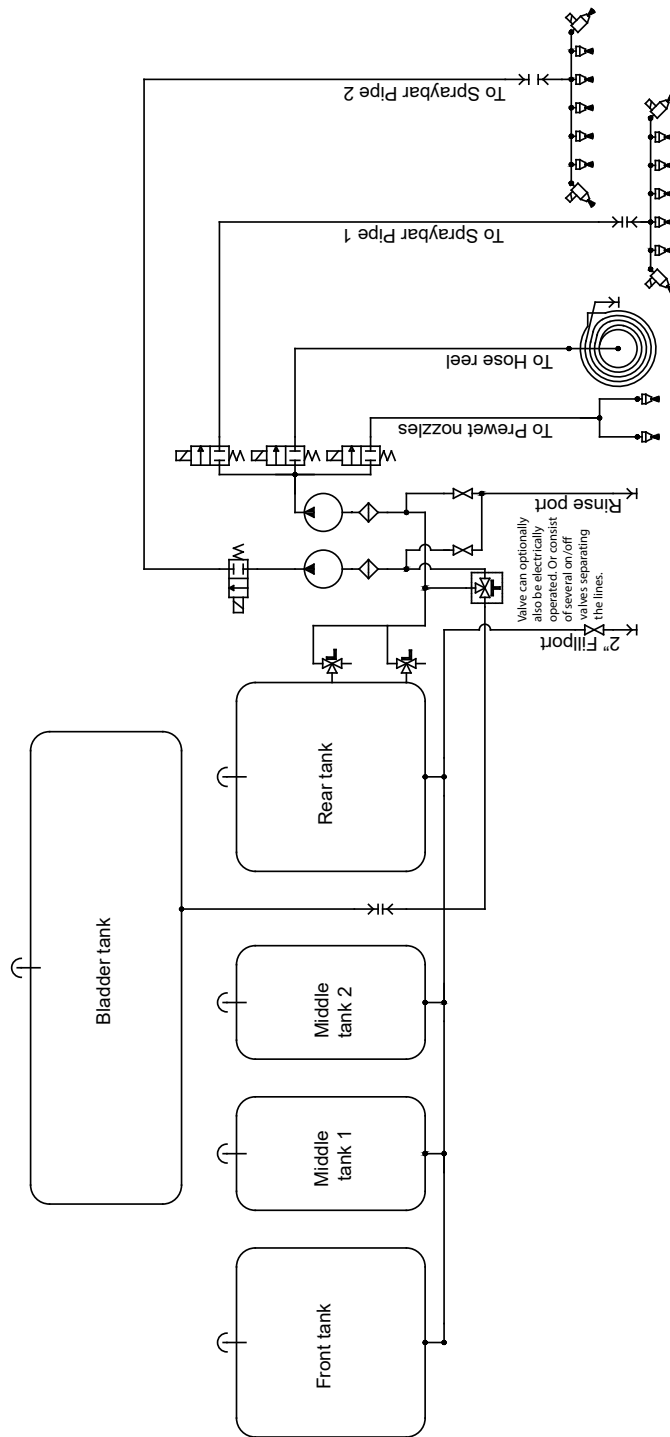

NOTE! Non-Current production model, serial number up to → XXXXX.20220519.010583

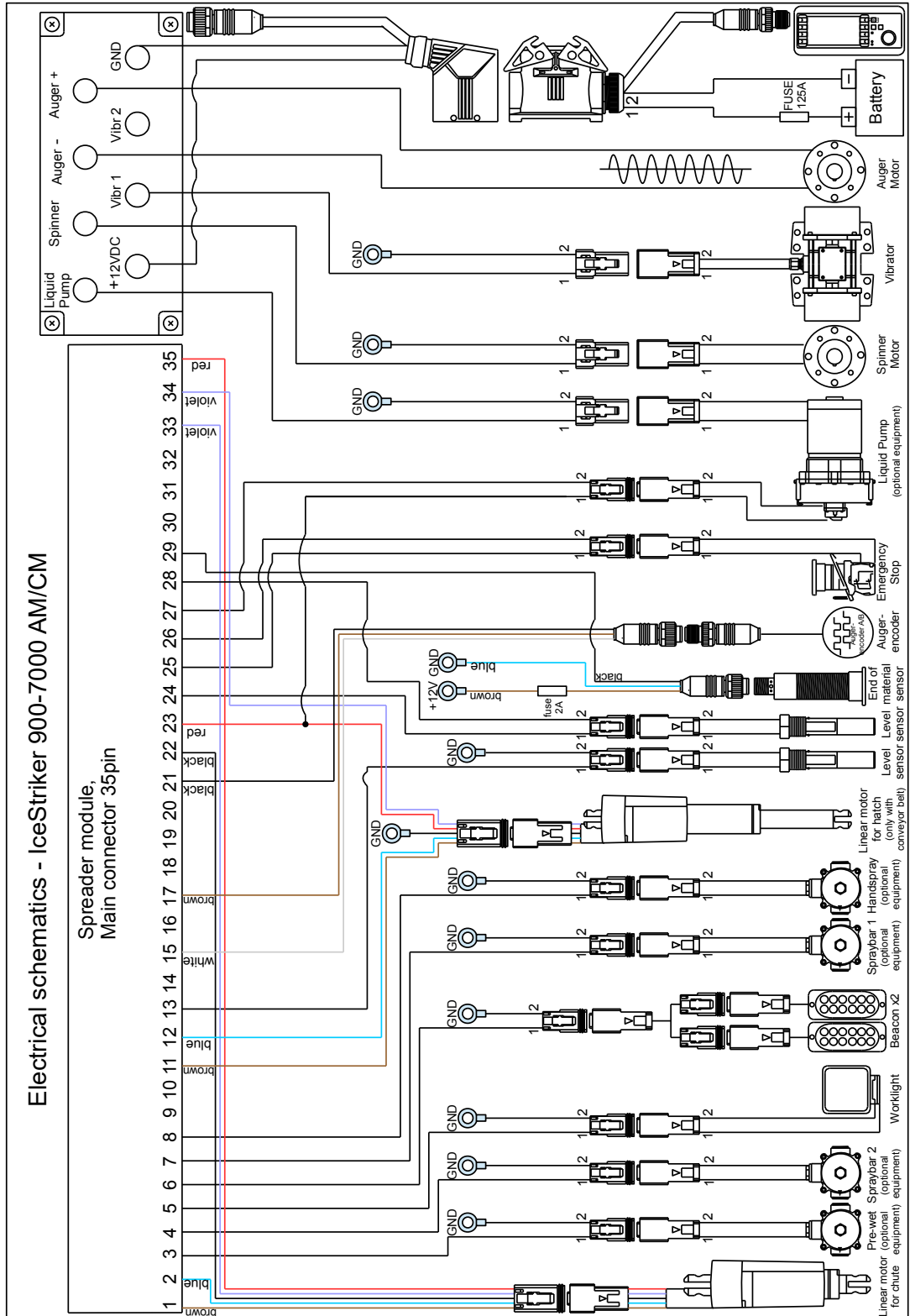

Warranty information

This warranty replaces all previous warranties

Warranty

Thank you for your interest in the products and services of Oy Hilltip Ab. This Limited Warranty applies to snowplows, spreaders, sweepers and other products and parts (from now on referred to as the "Product") purchased from Hilltip or an authorized dealer.

What does this limited warranty cover?

This Limited Warranty covers any defects in material or workmanship under normal use during the Warranty Period.

During the Warranty Period, Hilltip, or an authorized dealer will repair or replace, at no charge, products or parts of a product that proves defective because of improper material or workmanship, under normal use and maintenance.

How long does the coverage last?

The Warranty Period for the product purchased from Hilltip, or an authorized dealer is two (2) years from the date of purchase. The warranty period for a replacement part is one (1) year from the date of replacement or repair.

How to obtain warranty on your product?

Make sure your dealer has registered your product. In order to obtain service under this warranty the product must be registered with the end user's contact details (name, address, e-mail address and phone number).

What does this limited warranty not cover?

- Improperly installed parts.
- Damage caused by usage that is not in accordance with product instructions.
- Modification of the product, and/or the vehicle, is entirely at the purchaser's risk.
- This warranty does not include compensation for the drive to the service spot.
- Any damage in transit will be the responsibility of the carrier or at the risk of the purchaser.
- Hilltip will not provide replacement equipment or cover rental costs while your equipment is out of service.

This Limited Warranty does not cover any problem that is caused by:

- Misuse, neglect, accident, improper installation, maintenance or storage, or repair or alternation by anyone except Hilltip or an authorized dealer.

What do you have to do?

To obtain warranty service, you must first contact us or your authorized dealer. The purchaser must notify Hilltip or an authorized dealer within ten (10) days after any defect in the product becomes known during the warranty period.

What will we do to correct problems?

Hilltip, or an authorized dealer will repair or replace the part at no charge using either new or refurbished replacement parts.



DECLARATION OF CONFORMITY

Manufacturer's & Assambler's Name: **Oy Hilltip Ab**

Manufacturer's & Assambler's Address: **Pukkisaarentie 6, FIN-68600 Pietarsaari, Finland**

Equipment Description: Salt, Sand and Fertilizing Spreader and Spray applications, 900-7000 liter

Equipment Model Designation: Hilltip IceStriker™ 900 AM	Hilltip IceStriker™ 3000 AM/CM
Hilltip IceStriker™ 1150 AM	Hilltip IceStriker™ 4000 AM/CM
Hilltip IceStriker™ 1250 AML	Hilltip IceStriker™ 5000 CM
Hilltip IceStriker™ 1600 CM	Hilltip IceStriker™ 6000 CM
Hilltip IceStriker™ 2100 CM	Hilltip IceStriker™ 7000 CM
Hilltip IceStriker™ 2600 CM	

Equipment applications: Trucks and trailers

The equipments specified above are manufactured, where applicable, in conformity with provisions of the normative document according to the following directives and standards, in addition to relevant Road Traffic Regulations in European countries:

- 2006/42/EC
- EN 15597-1
- EN 15597-2
- ECE R10

I, the undersigned, hereby declare that the equipments specified above, that have been assambled by Oy Hilltip Ab, conforms to the above directives and standards

Pietarsaari, 08 December 2025

Signature:

Printed Name: Tom Mäenpää

Title: CEO

Installer's Name:

Installer's Address:

Type:

Serial number:

Year of installation:

I, the undersigned, hereby declare that the equipment installation to the vehicle specified above conforms to the directive 2006/42/EC and relevant Road Traffic Regulations.

DATE:

Signature:

Printed:

Title:

Product EOL (End Of Life)



The body of this product is made of **LLDPE plastic**, a **100% recyclable** material.

For proper disposal, please contact your local recycling center for further instructions or advice.



Oy Hilltip Ab

Pukkisaarentie 6
FIN-68600 Pietarsaari
Finland

www.hilltip.com
info@hilltip.com

Construction, specifications and other details are subject to change without notice.