



Snow **STRIKER™**



OWNER'S MANUAL

1450-1850 LIGHTWEIGHT STRAIGHT-BLADE

This manual replaces all editions with an earlier date.

Table of contents

TECHNICAL SPECIFICATIONS	3
SAFETY	4
Safety instructions	4
Warning and caution labels	5
INSTALLATION & OPERATION	6
Plow harness placement	6
Push beam installation height	7
Motor valve	7
Quick hitch instructions	8
Joystick	9
Error codes	10
MAINTENANCE	11
MECHANICS GUIDE	12
Valve Electrical functions	12
Hydraulic schematics	13
LS plow side electrical schematics	14
Vehicle side electrical schematics	15
WARRANTY INFORMATION	16
DECLARATION OF CONFORMITY	17



CAUTION - Read this manual before installing or operating the snowplow

Technical specifications

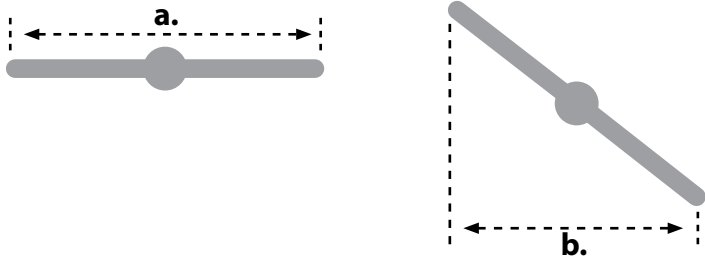

MODEL	1450 LS	1650 LS	1850 LS
Width (a.)	145 cm	165 cm	185 cm
Width, windrow position (b.)	120 cm	140 cm	160 cm
Height	55 cm	55 cm	55 cm
Weight	105 kg	110 kg	115 kg
Vehicle	Municipal vehicles with a low front axle rating, e.g., electric vehicles		

Center of gravity

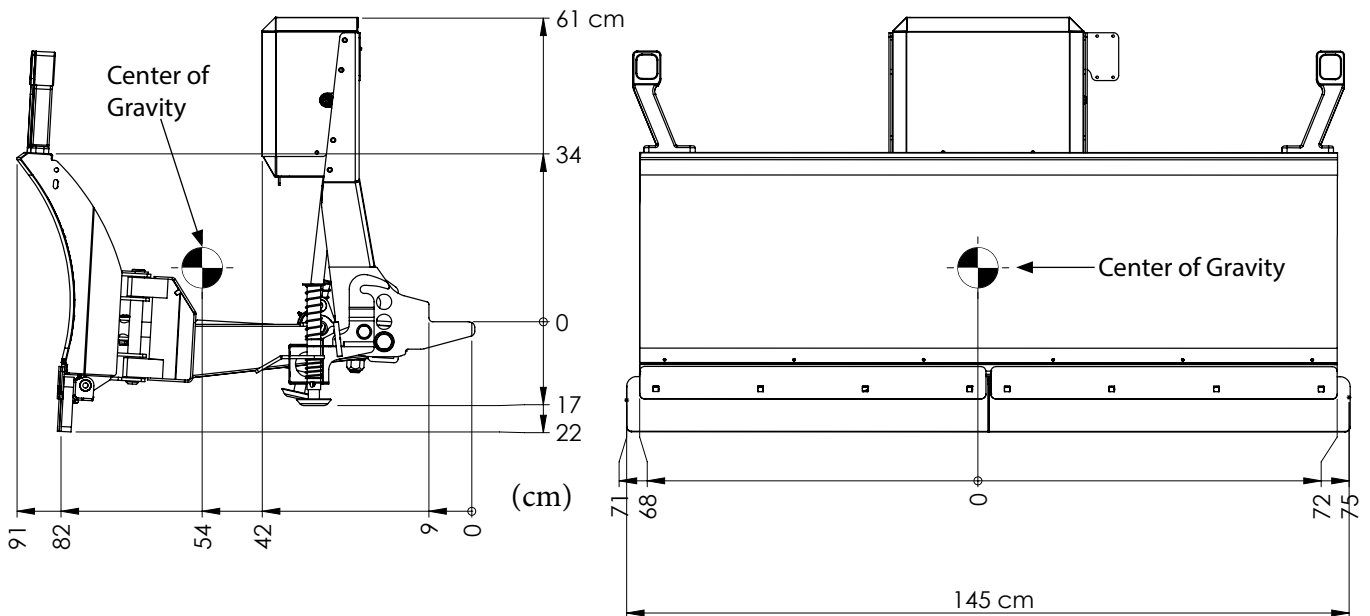

Safety instructions

Incorrect installation and operation can lead to serious personal injury and/or damage your equipment and property. Note and ensure that you understand this manual and all the labels before installing, operating or making adjustments to the snowplow.

 **WARNING**
Observe these safety precautions before, during and after operating the snowplow. You can prevent injury to persons and damage to the plow by following these precautions.

 **WARNING**
Before operating snowplow:

- Read this manual before operating the snowplow.
- Make sure that your vehicle total weight is not exceeded beyond payload limits.
- Inspect hydraulic components and hoses
- Check the snowplow and its components for cracks and defects before every plowing-session
- Replace any damaged or worn parts, a snowplow in need of repairs or maintenance should not be operated.
- Make sure the equipment is securely and correctly mounted.

 **WARNING**
Maintenance of the snowplow:

- Before removing or replacing any electrical components, always disconnect the battery.
- Use a piece of cardboard or wood to detect a suspected hose leak. Do NOT use your hand to locate it, hydraulic fluid can damage your skin.

Personal safety

- To prevent accidents, secure long hair and do not wear jewelry or necktie, only wear tight-fitting clothes while working on your plow or vehicle.
- Protect your eyes with safety goggles to avoid damage from battery acid, gasoline, dirt and dust.

 **WARNING**
While operating snowplow:

- Make sure that bystanders keep a safe distance (3 m) when the blade is being operated, raised, lowered or angle. Don't stand between vehicle and blade, a moving or falling blade can cause personal injury.
- Transport speed should not exceed 70km/h
- Plowing speed should not exceed 15 km/h

 **WARNING**
After operating snowplow:

- Lower the plow when vehicle is parked. The hydraulic pressure can change if temperature changes, causing an unexpected plow drop which can lead to plow damage or personal injury.

Warning and caution labels

Please become familiar with these warning and caution labels on the plow.

Snow STRIKER

AN ORIGINAL HILLTIP PRODUCT

MOUNTING INSTRUCTIONS

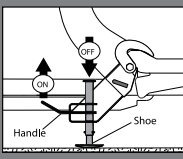
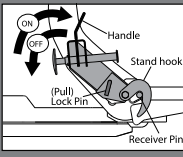
<p>MOUNTING PLOW (ON)</p> <p>STEP 1 After seating plow horns in receiver push beam, pull Handle up; Shoe will lift off the ground.</p> <p>STEP 2 Pull and hold Lock Pin out; then rotate Handle UP and release Lock Pin. It must lock into UPPER hole. Stand Hook must grip Receiver Pin.</p> <p>STEP 3 Plug in electrical connections. Repeat steps 1 and 2 on other side of plow</p>	 <p>Labels: Handle, Shoe</p>  <p>Labels: Handle, Stand hook, (Pull) Lock Pin, Receiver Pin</p>	<p>REMOVING PLOW (OFF)</p> <p>STEP 1 After lowering blade and turning control off, disconnect electrical connections.</p> <p>STEP 2 Pull and hold Lock Pin out; then rotate Handle DOWN and release Lock Pin. It must lock into LOWER hole.</p> <p>STEP 3 Push down top of Shoe; Shoe will be on the ground. Repeat steps 2 and 3 on other side of plow. Back vehicle away.</p>
--	--	---

Read Owner's Manual for complete instructions!

⚠ **WARNING**



Crush hazard

Keep hands and feet clear.

Plow harness placement

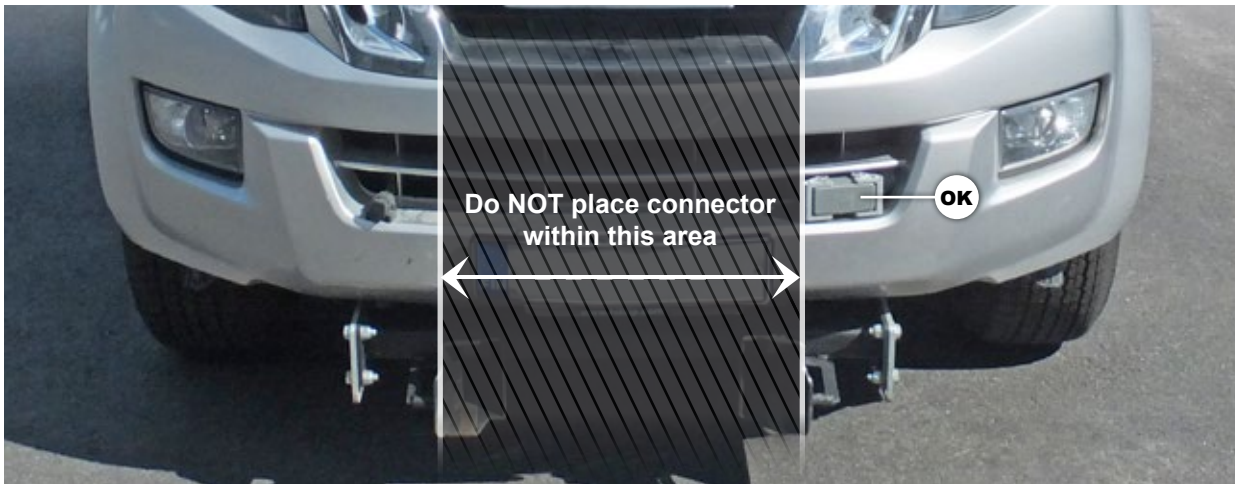

1. Fasten the connector to the bracket with four bolts.



2. Fasten the connector-assembly far into the bumper to make it less visible

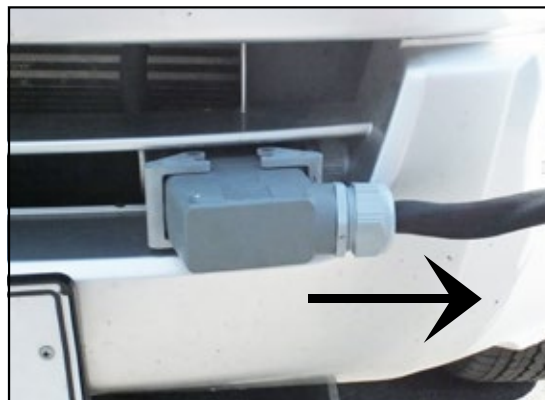

3. Harness should point outwards

Push beam installation height

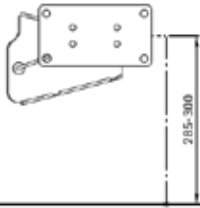

Optimal push beam
installation height
is 285-300 mm.



NOTE

A-frame should be horizontally aligned when plow is attached to vehicle and lowered to the ground.

High installation: 325-340 mm
Normal installation: 285-300 mm
Low installation: 225-260 mm

Motor valve

Straight blade

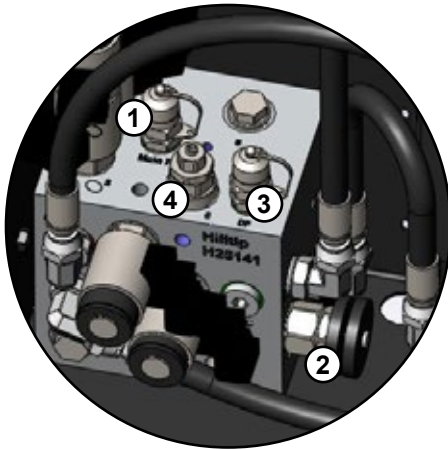

1. Main pressure
2. Adjust drop speed
3. Down pressure gauge port
4. Down pressure adjustment

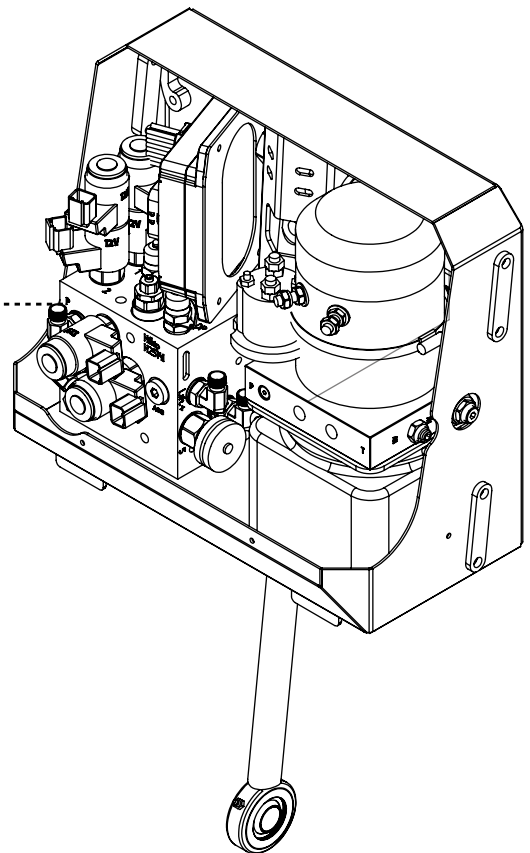

Quick hitch instructions



1 Plow must be standing steady on the ground, with plow shoes lowered



2 Align car and snow plow, slowly drive car forward

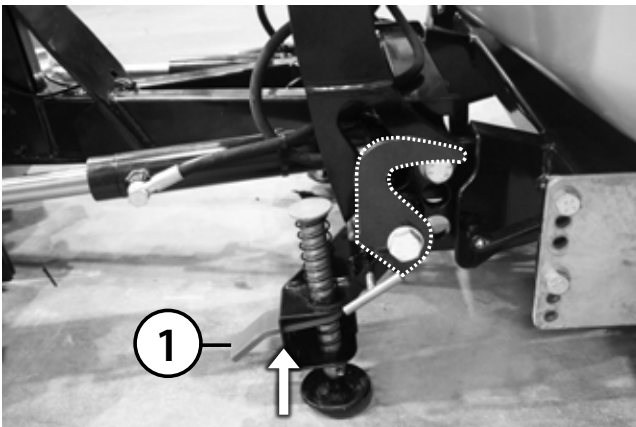

3 Fit the plow horns in receiver push beam, pull handle (1) up, the shoe will lift off the ground

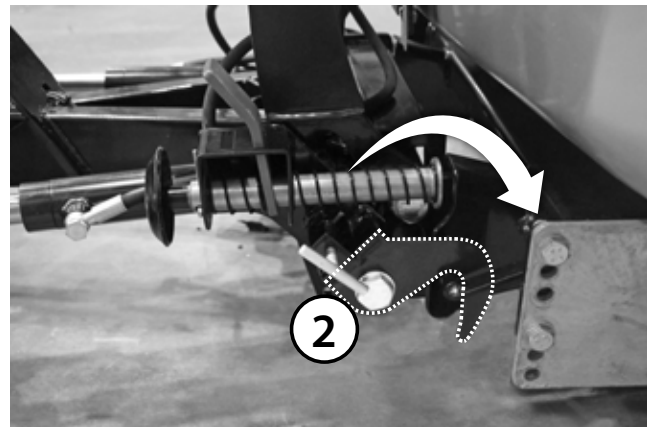

4 Pull and hold the lock pin out (2), rotate handle up and release lock pin

Joystick

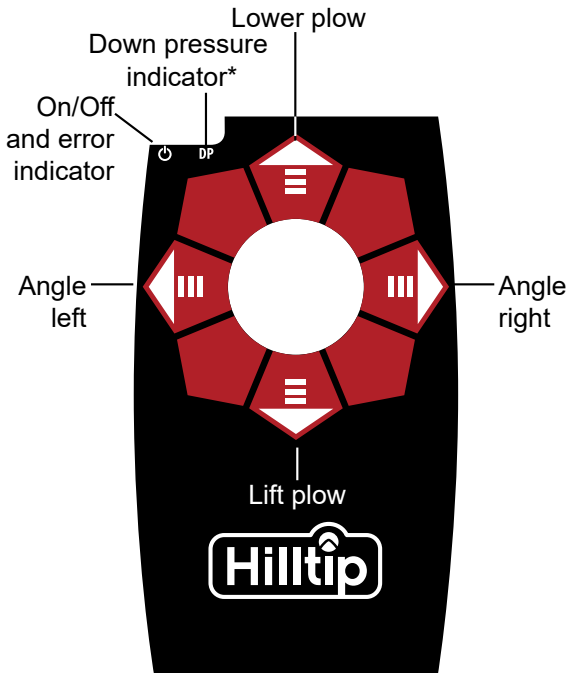

* Down pressure function

Push the joystick knob upwards (lower plow-position) for more than 3 seconds to apply down pressure. This function presses the snowplow down to the ground to give you a cleaner scrape when plowing.

The downpressure-function will automatically be deactivated 30 seconds after it has been applied.

Automatic shut-down

The joystick/IO module and snowplow will automatically shut down after being inactive for 5 minutes. To reactivate, move joystick knob or turn it off and on again.

Change software mode in joystick

It is possible to switch between different operation mode. To change mode:

1. Switch off joystick.
2. Hold joystick knob in one of following directions and switch joystick **on** at the same time:

Joystick position	Software option	Comments
RIGHT	V-plow produced from 2017 with valve block H25142	
LEFT	Straight plow	
FORWARD	V-plow produced before 2017 with valve block H23270	
FORWARD + RIGHT	V-plow, move wings independently	Supported in version 10
BACKWARDS + BUTTON	V-plow, Hiltip button logic	Supported in version 18
RIGHT + BUTTON	V-plow, independent wing with button	Supported in version 23

3. Hold for approx. 6 seconds, until the orange DP led lights up.

NOTE! To select the “Hydraulic accumulator” function, you must hold the joystick for another 3 seconds after the DP light starts to light up until the DP light starts flashing rapidly. The hydraulic accumulator function is available in version 18 and onwards.

4. Release joystick.
5. Now joystick is programmed and ready to use.

Error codes

The on/off and error indicator LED located in the upper left corner of the joystick will show a green light when turned on and if no errors are detected. If a problem is detected, the LED will flash with a red light a number of times, pause, and then repeat.

Straight-blade error codes:

Type/number of flashes	Problem
Green light	No errors detected
Constant red light	Communication problem between IO box and joystick
1 flash	Valve #1a or #1b not connected, or broken cable/coil
2 flashes	Valve #2a or #2b not connected, or broken cable/coil
3 flashes	Valve #3 or #4 not connected, or broken cable/coil

Maintenance

Follow this checklist to keep your snowplow in good condition and to be able to maintain full warranty for possible damages.

Periodical maintenance checklist	Yearly maintenance checklist
Check that fasteners are tight enough.	Pressure wash and dry the plow carefully before putting it in storage.
Check for scratches and exposed metal, clean and apply touch-up paint.	
Clean and apply dielectric grease on all electrical plugs and connectors. Clean and install all dust caps before placing your plow in storage.	
Lubricate all pins, bushings and the A-frame latch.	
Inspect hydraulic components, hoses and cylinders, check for leaks and wear.	Lubricate all exposed cylinder rod ends with liquid white lithium grease to prevent corrosion.
Inspect rod ends for corrosion and pitting.	Change oil every 100th hour or annually. Empty the pump fluid reservoir, discard the old fluid properly. Clean pump filter and fill the reservoir with new hydraulic fluid to 2 cm from the top. By changing the fluid annually, the pump and manifold lifetime will be extended. Never mix different fluid types.
Check cutting edges for wear.	
Check the hydraulic fluid level. Fill with fluid to 2 cm from the top of the reservoir, do not exceed this level. Never mix different fluid types. Change oil every 100th hour or annually.	
Remove snow and ice build-up from the pump and A-frame.	Cover the snowplow with a tarp during storage, to protect it from sun fading and other weather conditions and circumstances.

For the snowplow hydraulic system we recommend using: **ISO VG 15 - Teboil hydraulic Arctic oil**

Grease fittings:

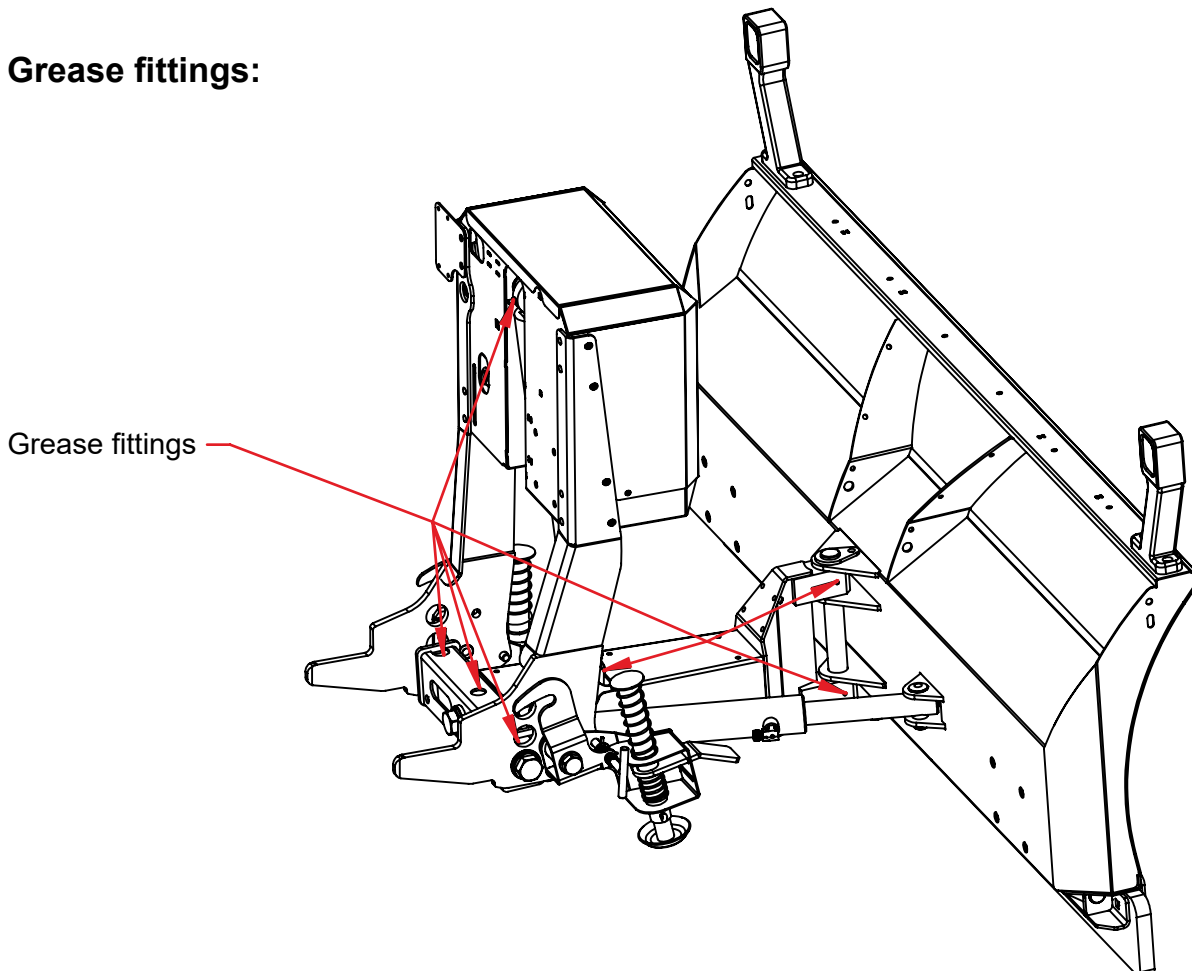

Straight-blade valve electrical functions

Blade movement	Angle right	Angle left	Down pressure	Raise	Lower	Idle	Float
MOTOR			*				
#1a							
#1b							
#2a							
#2b			*				
#3							
#4							

1* = Goes low after 30 sec.

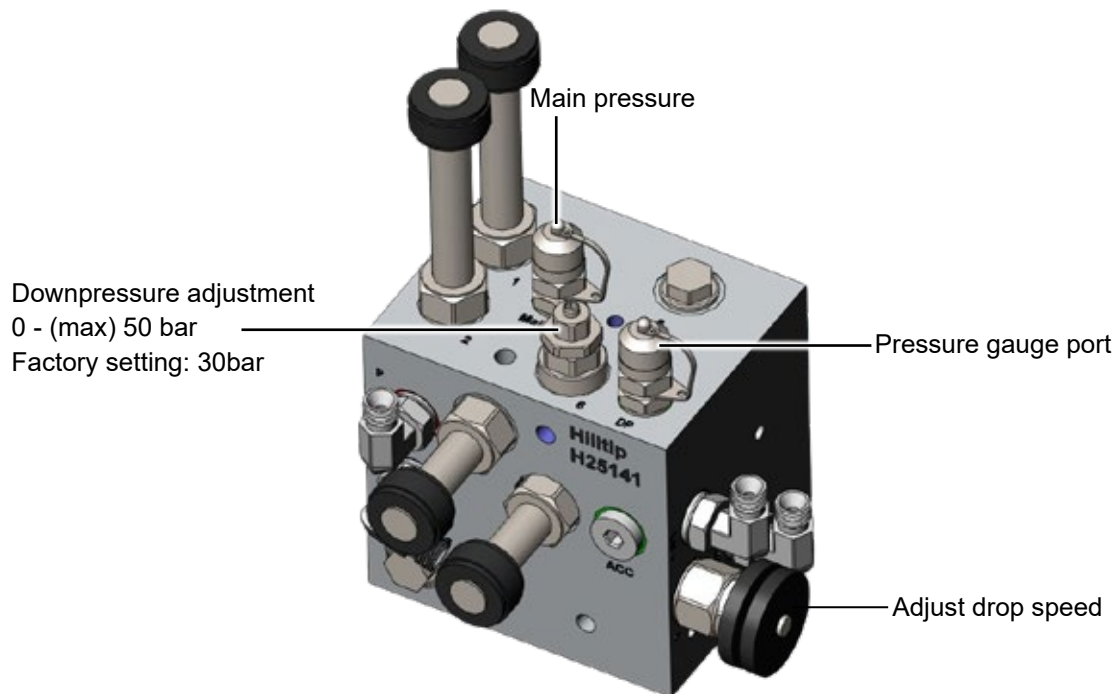

1450-1850 LS- Plow side electrical schematics

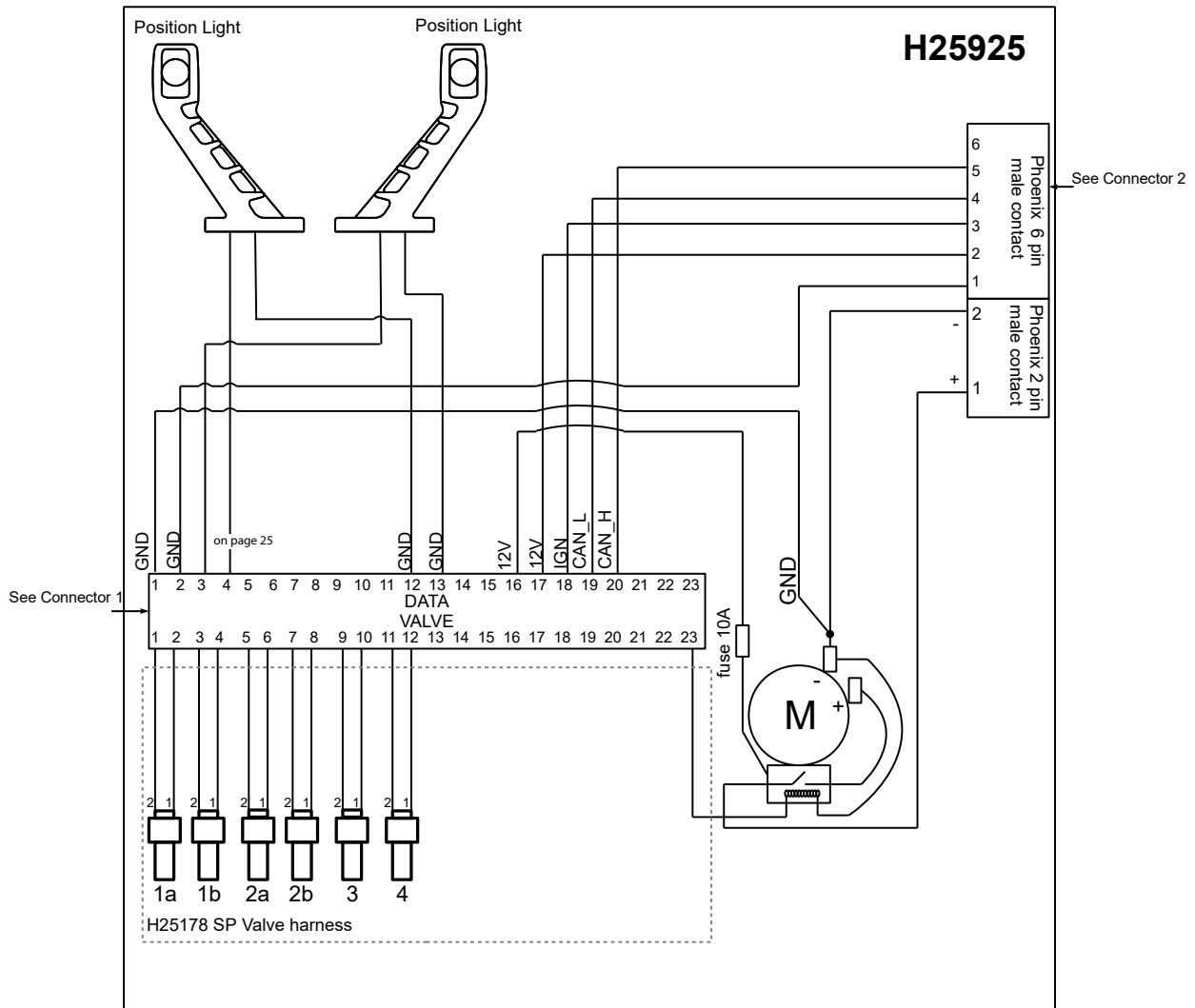

Connector 1:
23-pin
connector

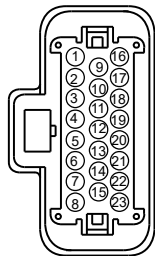

Connector 2:
Phoenix 6-pin plow
side connector

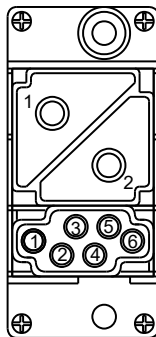

Vehicle side electrical schematics

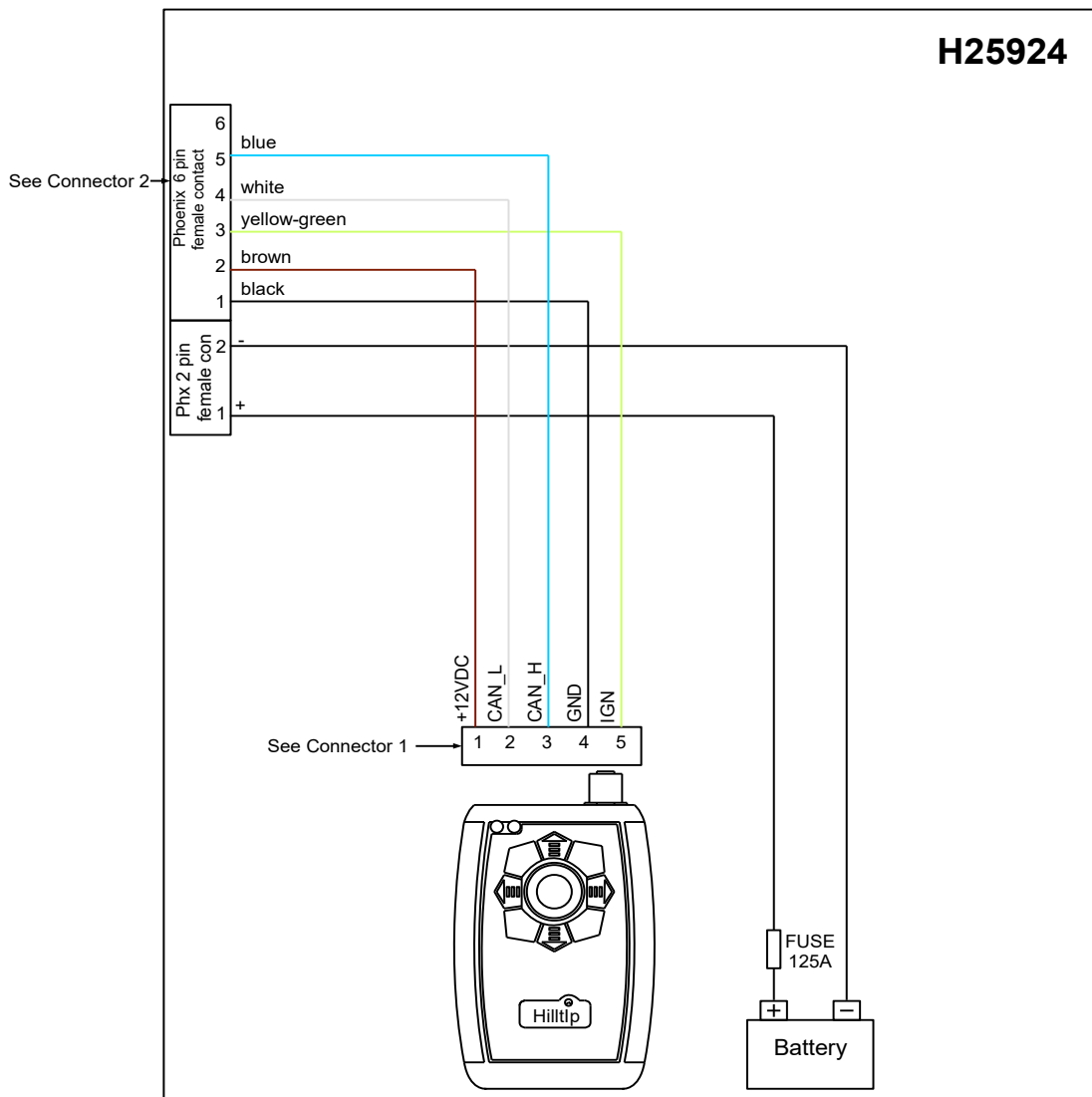

Connector 1:
Connector to joystick (male)

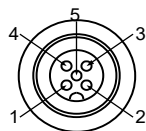

1. +12VDC
2. CAN_L
3. CAN_H
4. GND
5. Activation

Connector 2:
Phoenix 6-pin vehicle side connector

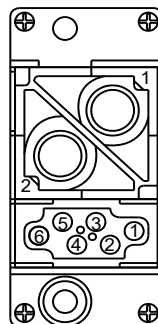

Warranty information

This warranty replaces all previous warranties

Warranty

Thank you for your interest in the products and services of Oy Hilltip Ab. This Limited Warranty applies to snowplows, spreaders, sweepers and other products and parts (from now on referred to as the "Product") purchased from Hilltip or an authorized dealer.

What does this limited warranty cover?

This Limited Warranty covers any defects in material or workmanship under normal use during the Warranty Period.

During the Warranty Period, Hilltip, or an authorized dealer will repair or replace, at no charge, products or parts of a product that proves defective because of improper material or workmanship, under normal use and maintenance.

How long does the coverage last?

The Warranty Period for the product purchased from Hilltip, or an authorized dealer is two (2) years from the date of purchase. The warranty period for a replacement part is one (1) year from the date of replacement or repair.

How to obtain warranty on your product?

Make sure your dealer has registered your product. In order to obtain service under this warranty the product must be registered with the end user's contact details (name, address, e-mail address and phone number).

What does this limited warranty not cover?

- Improperly installed parts.
- Damage caused by usage that is not in accordance with product instructions.
- Modification of the product, and/or the vehicle, is entirely at the purchaser's risk.
- This warranty does not include compensation for the drive to the service spot.
- Any damage in transit will be the responsibility of the carrier or at the risk of the purchaser.
- Hilltip will not provide replacement equipment or cover rental costs while your equipment is out of service.

This Limited Warranty does not cover any problem that is caused by:

- Misuse, neglect, accident, improper installation, maintenance or storage, or repair or alternation by anyone except Hilltip or an authorized dealer.

What do you have to do?

To obtain warranty service, you must first contact us or your authorized dealer. The purchaser must notify Hilltip or an authorized dealer within ten (10) days after any defect in the product becomes known during the warranty period.

What will we do to correct problems?

Hilltip, or an authorized dealer will repair or replace the part at no charge using either new or refurbished replacement parts.



DECLARATION OF CONFORMITY

Manufacturer's & Assambler's Name: **Oy Hilltip Ab**

Manufacturer's & Assambler's Address: **Pukkisaarentie 6, FIN-68600 Pietarsaari, Finland**

Equipment Description: Hilltip Snowplow Applications

Equipment Model Designation: Hilltip SnowStriker™ 1450 LS, 1650 LS, and 1850 LS

Equipment applications: Municipal vehicles with a low front axle rating, e.g., electric vehicles.

The equipments specified above are manufactured, where applicable, in conformity with provisions of the normative document according to the following directives and standards, in addition to relevant Road Traffic Regulations in European countries:

- 2006/42/EC
- EN 15432-1
- 2009/433/EG
- ECE R10

I, the undersigned, hereby declare that the equipments specified above, that have been assambled by Oy Hilltip Ab, conforms to the above directives and standards

Pietarsaari, August 12, 2024

Signature:

Printed Name: Tom Mäenpää

Title: CEO

Installer's Name:

Installer's Address:

Type:

Serial number:

Year of installation:

I, the undersigned, hereby declare that the equipment installation to the vehicle specified above conforms to the directive 2006/42/EC and relevant Road Traffic Regulations.

DATE:

Signature:

Printed:

Title:



Oy Hilltip Ab

Pukkisaarentie 6
FIN-68600 Pietarsaari
Finland

+358 50 5983 026

www.hilltip.com
info@hilltip.com